



Operating Instructions Safety Cabinets

**Safe 2020
Maxisafe 2020**

© 2008 Thermo Fisher Scientific Inc. All rights reserved.

These operating instructions are protected by copyright. Rights resulting thereof, particularly reprint, photomechanical or digital postprocessing or reproduction, even in part, are only allowed with the written consent of Thermo Electron LED GmbH. This regulation does not apply to reproductions for in-plant use.

Trademarks

All trademarks mentioned in the operating instructions are the exclusive property of the respective manufacturers.

Thermo Electron LED GmbH
Robert-Bosch-Straße 1
D - 63505 Langenselbold
Germany

Contents

1. General notes	6
1.1 General safety instructions	6
1.2 Warranty	7
1.3 Explanation of symbols	7
1.3.1 Symbols used in the operating instructions	7
1.3.2 Symbols on the device	8
1.4 Use of the device	8
1.4.1 Correct use	8
1.4.2 Incorrect use:	9
1.5 Standards and safety regulations	9
2. Delivery	10
2.1 Standard components	10
2.2 Acceptance inspection	10
2.3 Transport lock and device packaging	10
3. Installation	11
3.1 Ambient conditions	11
3.2 Room ventilation	11
3.3 Correct location	12
3.4 Installation in line	12
3.5 Transport	13
4. Unit description	14
4.1 Overall view	14
4.2 Safety system	17
4.3 Filter system	18
4.4 Controls and display	20
4.5 Sample chamber access	21
4.6 Device interfaces	22
4.7 Sample chamber illumination	23
4.8 UV lamp unit	24
4.9 Working area	24
5. Start-up	25
5.1 Initial operation	25
5.2 Installing unit and accessories	25
5.3 Levelling the cabinet	27
5.4 Power supply connection	28
5.5 RS 232 interface connection	30
5.6 UV connection	30
5.7 Installation test	31
6. Handling and control	32
6.1 Display	32
6.1.1 Functions of the display components	32
6.1.2 Display during the calibration routine	33
6.1.3 Display in OFF mode	33
6.1.4 Display in work mode	33
6.1.5 Power interruption	33
6.1.6 Display and functions after a power failure	34
6.1.7 Failure messages	34
6.2 Description of the operating modes	35
6.3 Operation system	37
6.3.1 Basic functions	37
6.3.2 Moving the front window to the working position	39
6.3.3 Silencing the audible alarm signal	39
6.3.4 Switching the illumination on and off	40

Contents

6.3.5	Activating and deactivating the internal power supply	40
6.3.6	Displaying the UV disinfection time	40
6.3.7	Activating and deactivating the potential-free contact (optional)	40
6.3.8	Switching the cabinet to OFF mode	41
6.3.9	Setting the time	41
6.3.10	Displaying the downflow velocity	42
6.3.11	Displaying the operating hours of the HEPA filters	43
6.3.12	Displaying the Performance Factor	43
6.3.13	Setting and activating the timer	44
6.3.14	Deactivating the timer	45
6.3.15	Setting the UV disinfection time	46
6.3.16	Starting the UV disinfection	46
6.3.17	Cancelling the UV disinfection	47
6.3.18	Activating the stop watch	47
6.4	Pilot switch	48
6.4.1	Moving the front window	48
6.4.2	Switching the device to OFF mode	49
7.	Operation	50
7.1	Hygiene preparations for the sample chamber	50
7.2	Preparing the sample chamber	50
7.3	Response to failure messages	50
7.4	Work rules	51
8.	Shut-down	52
8.1	Interrupting an operation	52
8.2	Shutting the unit down	52
9.	Cleaning and decontamination	53
9.1	Decontamination procedure	53
9.2	Wipe/spray disinfection	53
9.3	UV disinfection after a wipe/spray disinfection	54
9.3.1	UV disinfection using the integral UV lamps	54
9.3.2	UV disinfection using a mobile UV device	55
9.3.3	Changing the UV disinfection time	55
9.4	Sterilization with formaldehyde	56
9.5	Cleaning the exterior surfaces	56
9.6	Cleaning the floorpan	56
10.	Maintenance	57
10.1	Inspection	57
10.2	Service	57
10.2.1	UV lamps	57
10.2.2	Sample chamber illumination	58
10.2.3	Replacing the front window seal	58
10.3	Retrofitting and repairs	59
11.	Disposal	60
11.1	Disposal procedure	60
12.	Technical data	62
13.	Device log	69
14.	Certificate of decontamination	70

Figures

Fig. 1	Device locations in a room	12
Fig. 2	Lift points	13
Fig. 3-a	Overall view / model Safe 2020	15
Fig. 3-b	Overall view / model Maxisafe 2020	16
Fig. 4-a	Filter system with downflow filter and exhaust air filter / model Safe 2020	18
Fig. 4-b	Filter system with primary filter, downflow filter and exhaust air filter / model Maxisafe 2020	19
Fig. 5	Controls and indicators	20
Fig. 6-a	Access through front cover	21
Fig. 6-b	Access through front window	21
Fig. 7-a	Supply interfaces	22
Fig. 7-b	Sample chamber illumination	23
Fig. 8	UV lamp unit	24
Fig. 9	Working area on the workplate, armrests	24
Fig. 10-a	Stand installation / model Safe 2020	25
Fig. 10-b	Stand installation / model Maxisafe 2020	26
Fig. 10-c	Drain valve installation	27
Fig. 11	RS 232 interface connection	30
Fig. 12	UV connection	30
Fig. 13	Indicator and operating panel	33
Fig. 14	Indicator and operating panel	37
Fig. 15	Basic functions of the pilot switch	48
Fig. 16	Sitting posture	52
Fig. 17	Front window seal replacement	58

1. General notes

The following are the addresses of the international Thermo Sales Organisations.

Postal address Germany

Thermo Electron LED GmbH
Robert-Bosch-Straße 1
D - 63505 Langenselbold

Enquiries from Germany:

Phone

Sales 0800 1 536376
Service 0800 1 112110

Fax

Sales/Service 0800 1 112114

E-Mail

info.labequipment.de@thermofisher.com

International enquiries

Tel. + 49 (0) 6184 / 90-6940

Fax + 49 (0) 6184 / 90-6772

E-Mail

info.labequipment@thermofisher.com

1.1 General safety instructions

These safety instructions describe the safety features of the Safe 2020 and Maxisafe 2020 series.

The safety cabinet has been manufactured in keeping with the latest technological developments and has been tested before delivery for its correct function. It may, however, present potential hazards if it is not used according to the intended purpose or outside of operating parameters. Therefore, the following procedures must always be observed:

- The safety cabinet must be operated only by trained and authorized personnel.
- For any operation of this unit, the operator must prepare clear and concise written instructions in the language of the operating and cleaning personnel based on these operating instructions, applicable safety data sheets, plant hygiene guidelines, and technical regulations, in particular:
 - which decontamination measures are to be applied for the cabinet and accessories,
 - which protective measures apply while specific agents are used,
 - which measures are to be taken in the case of an accident.
- Repairs to the device must be carried out only by trained and authorized expert personnel.
- The contents of the operating instructions are subject to change without further notice.
- Concerning translations into foreign languages, the German version of these operating instructions is binding.
- Keep these operating instructions close to the unit so that safety instructions and important information are always accessible.
- Should you encounter problems that are not detailed adequately in these operating instructions, please contact Thermo Electron LED GmbH immediately for your own safety.

1.**General notes****1.2 Warranty**

Thermo Electron LED GmbH warrant the operational safety and functions of the safety cabinet only under the condition that:

- the device is operated and serviced exclusively in accordance with its intended purpose and as described in these operating instructions,
- the device is not modified,
- only original spare parts and accessories that have been approved by Thermo Electron LED GmbH are used,
- inspections and maintenance are performed at the specified intervals,
- an installation test is performed prior to the initial operation of the device and that a repeat test is performed on the occasion of all inspections and repairs.

The warranty is valid from the date of delivery of the device to the operator.

1.3 Explanation of symbols**1.3.1 Symbols used in the operating instructions****WARNING!**

is used if non-observance may cause serious or even lethal injuries.

**CAUTION!**

is used if non-observance may cause medium to minor injuries or damage.

**NOTE**

is used for hints and useful information.

**RECYCLING!**

Valuable raw materials can be reused.

1. General notes

1.3.2 Symbols on the device



Betriebsanleitung beachten (Decke Schaltraum)



Observe operating instructions (cover electrical box)



ZYTOSTATIKA
CYTOTOXIC HAZARD

Cytostatic agents (left device front)



Checked safety (Cover light dome)



T5A note (sample chamber fusing)



RS 232 interface (connection label)

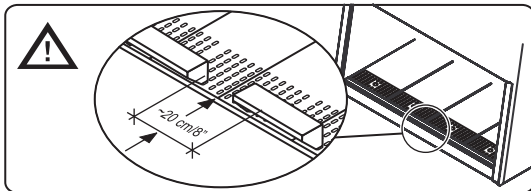

**Armrest installation
(right side of light dome)**

1.4 Use of the device

1.4.1 Correct use

Model Safe 2020:

The safety cabinet is a laboratory device for installation and operation in microbiological and biotechnical laboratories of safety levels 1, 2, and 3. It has been designed as a Class II microbiological safety cabinet, in accordance with EN 12469 / 2000.

Depending on the hazard level of the agents involved, the operator must prepare in writing appropriate decontamination procedures for the device and the accessories used in the sample chamber.

1.**General notes****Model Maxisafe 2020:**

The safety cabinet also meets the requirements from DIN 12980 / 2005-06 and can be used for the production of cytostatic agents.

For cytostatic agent applications, use the lowered one-piece working plate only.

Prior to the initial operation of the cabinet, the operator must perform an installation test. The test result must be documented by a test report. The cabinet must only be released for operation if it is in compliance with the operating parameters specified by Thermo Electron LED GmbH.

After any changes to the installation conditions or after any modification to the technical system, a repeat test must be performed and the test result must be documented by a test report that shows that all operating parameters are in compliance with those specified by Thermo Electron LED GmbH.

1.4.2 Incorrect use:

The safety cabinet must not be used in laboratories that do not comply with the requirements of safety levels 1, 2, and 3.

The unit must not be operated as a Class II safety cabinet, if:

- no repeat test is performed after changes to the installation conditions or after modifications to the technical system,
- the alarm system of the device has issued a failure message and the cause for the failure has not been repaired.

The alarm system must not be tampered with or disabled. If alarm system components have been removed or disabled for service or repairs, the unit must only be released for operation if all alarm system components are functioning again properly.

The filters installed in the device are not capable of separating gaseous substances. Therefore, do not work with or store substances in the device:

- which in quantity or concentration are toxic,
- if a reaction with other substances may result in hazardous toxic concentrations or formation of toxic gases,
- that may form combustible or explosive mixtures in combination with air.

1.5 Standards and safety regulations

The device complies with the safety requirements of the following standards and guidelines:

- IEC 61010-1 / EN 61010-1
- EN 12469 / 2000
- DIN 12980 / 2005-06
- Low Voltage Directive
- EMC Directive

2.**Delivery****2.1 Standard components**

Delivery for the safety cabinet includes the following:

Model Safe 2020:

- safety cabinet,
- drain valve.

Model Maxisafe 2020:

- safety cabinet
- armrests
- stand

All models:

- Device documentation:
 - operating instructions,
 - factory test report.

Optional components and accessories are listed as separate items in the delivery document.

2.2 Acceptance inspection

After the device has been delivered, immediately check the device:

- for completeness,
- for possible damage.

If the delivery is incomplete or if you detect any transport damage to the device, contact the forwarding agency and Thermo Electron LED GmbH immediately.

2.3 Transport lock and device packaging

Do not transport the device over large distances without transport lock and original device packaging.

3.**Installation****3.1 Ambient conditions**

The operational safety and correct function of the unit depend on the location where it is to be operated. The safety cabinet must be operated only at locations that meet the ambient conditions listed below.

Location requirements:

- The electrical system of the device has been designed for an operating height of up to 2000 m above sea level.
- The mains power supply outlets should be out of normal reach to prevent accidental shut-off. Ideally, the outlets should be installed above the safety cabinet.
- The flooring of the location must be adequately strong and not flammable.
- The room in which the device is installed must be of adequate height. For units not connected to an exhaust system, the distance between the exhaust air opening and the room ceiling must be at least 200 mm (8 in).
- The location must be equipped with an appropriate ventilation system (see Section 3.2.).
- The temperature within the room must be between 15 °C and 40 °C (49 °F and 104 °F).
- The relative humidity in the vicinity of the device must not exceed 90 %.

**NOTE - Ambient conditions**

If ambient conditions vary from those described above, please contact Thermo Electron LED GmbH for assistance in installing the device.

**NOTE - Temporary storage**

If the device is stored only temporarily (up to four weeks), the ambient temperature may be between -20 °C and +60 °C (-4 °F and +140 °F) at a relative air humidity of up to 90 %. For longer storage periods, the location requirements apply.

3.2 Room ventilation

The room ventilation should preferably be a ventilation system that complies with the national requirements for the application.

- The inlet air and exhaust air openings of the room ventilation must be located so that drafts are prevented from impairing the function of the safety cabinet air system.

3. Installation

3.3 Correct location

Choose a draft-free location where the safety cabinet does not interfere with the room traffic.

Fig. 1: This figure shows preferred locations for safety cabinets and unsuitable locations, not in accordance with the safety requirements.

Unsuitable locations: The locations [1], [2], and [3] are not suitable because they are exposed to drafts from windows and doors.

Location [5] is undesirable because it is in range of plant traffic and within the exhaust air range of a ventilation system [4].

Preferred locations [6], [7], and [8] are correct because they are in a draft-free section of the room and not exposed to plant traffic.

3.4 Installation in line

When several devices are to be installed in line, please observe the following:

- Make sure that vibrations cannot be transferred between adjacent units.
- Exterior surfaces of the cabinets must always be accessible for cleaning and disinfection.

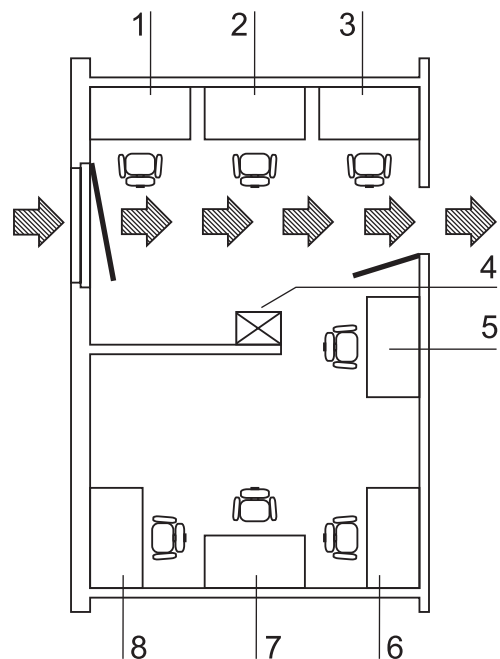

Fig. 1
Locations in a room

3. Installation

3.5 Transport

Model Safe 2020:

Fig. 2: To prevent tilting, always transport the device using a suitable carrier, even for a transport within a building, and separate it from the stand.



CAUTION – Danger of tipping over!

For transport, lift the device only using the lift points shown in the illustration. Do not load the floorpan with the weight of the device frame!



CAUTION – Contusion hazard!

When lifting the safety cabinet, do not put hands or fingers between floorpan and frame!

Model Maxisafe 2020:

If required, the device stand must be removed from the stand to be reinstalled onto the stand for the initial start-up after the transport (see Section 5.2).

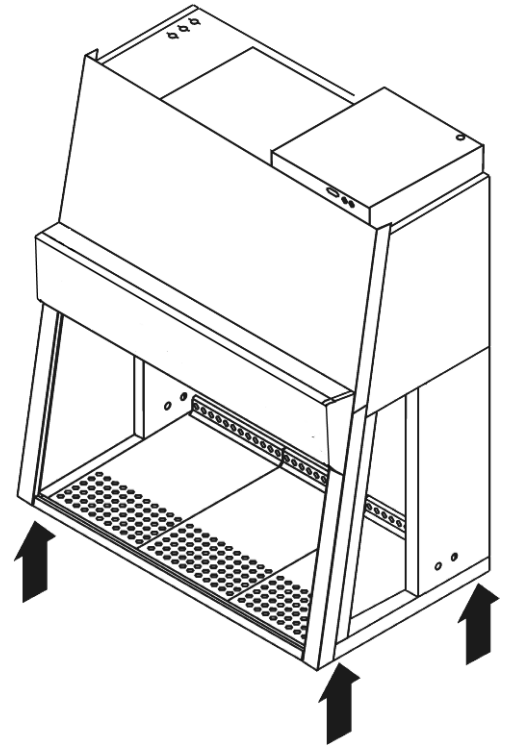

Fig. 2
Lift points

4. Unit description

4.1 Overall view

Model Safe 2020:

- **Fig. 3a:** Plenum assembly [5] with plenum for downflow blower [24] and plenum for exhaust air blower [2]. The downflow filter and the exhaust air filter are installed directly to the relevant blower. The exhaust air is released into the environment around the device through the opening [1].
- At the side of the plenum, the optional media supply lines [25] are routed into the sample chamber [20].
- Electrical box [4] with power supply cable [3]. An RS 232 connection to a PC and two fuse holders are installed at the front of the electrical box.
- Front cover [6] with integral, electrically movable front window [7], operated by:
 - the pilot switch [26].The gas struts [22] secure the front cover in the open state. Optionally, two safety latches [27] can be installed to the front cover so that the door can be protected against unauthorized opening.
- The light dome [23] with two tubes is part of the front cover assy.
- Side panels [9] with two sealed access openings [19]. These can be equipped with media valves [13].
- Internal outlets [10] for power supply of accessories and adapter [11] for mobile UV device.
- Optional UV lamp unit [8] consisting of two UV lamps per side.
- Optional stands [12], adjustable in height and with fixed height
- Workplate segments [15] with optional arm rests [16]. A one-piece workplate and special workplates are available options.
- Lockable drain valve [17] for installation into floorpan.
- Display [21] with alarm system indicators.
- Test hoses for the supply unit [18] at the left side of the sample chamber and for the exhaust unit [14] at the right side of the sample chamber.



NOTE – Test hoses

Do not remove the two test hoses for checking downflow and exhaust air.

4. Unit description

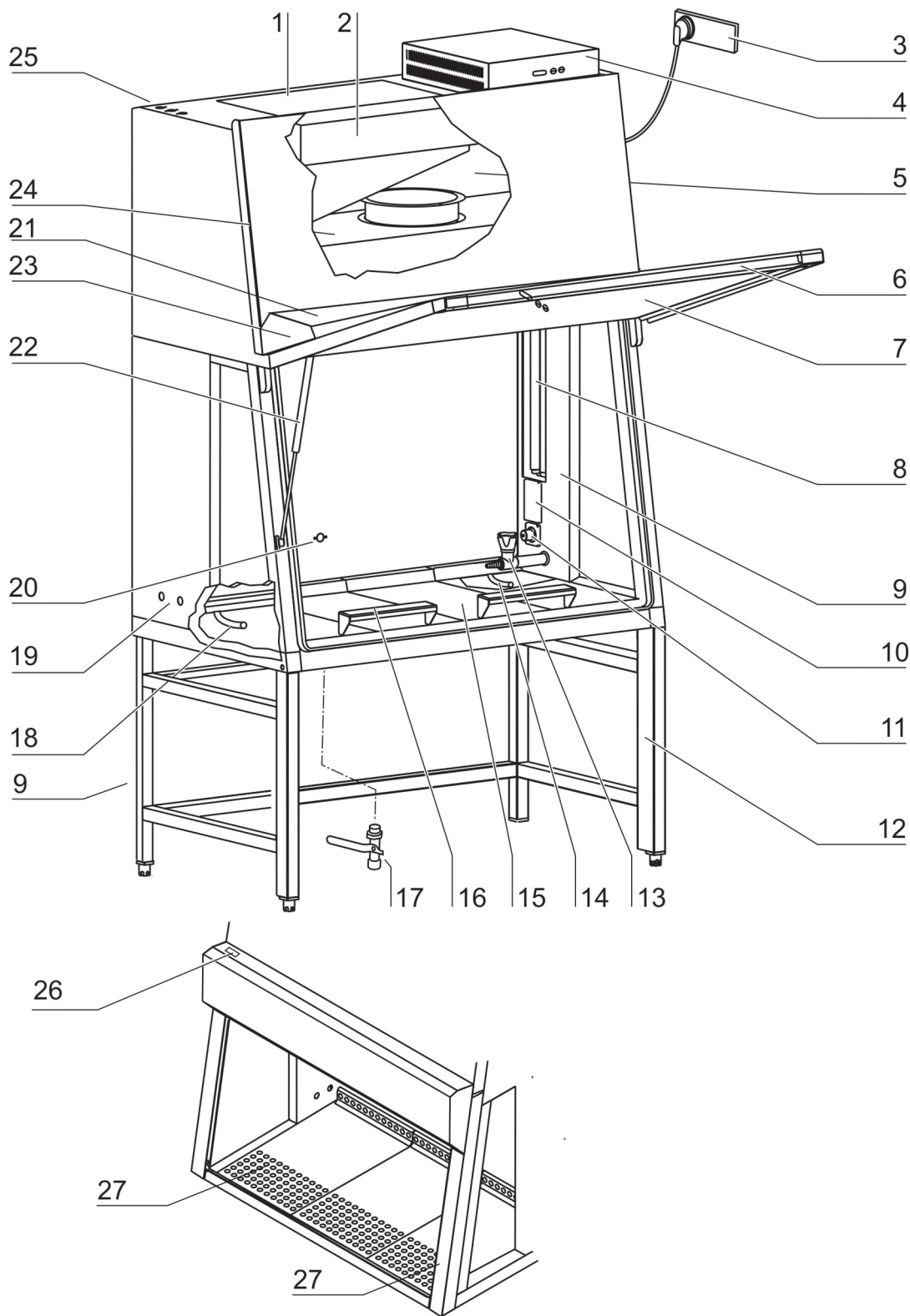

Fig. 3a
Overall view / Model Safe 2020

4. Unit description

Model Maxisafe 2020:

- **Fig. 3b:** Stand [5] with integral prefilter housing [6].
- Filter inserts [2] for the prefilter housing. The number of supplied filter inserts depends on the width of the device. To protect from liquid residues, the filter inserts are oriented slightly sloping from the device backpanel to form a drain duct to the floorpan [3]. The filter plates [4] have tongues and grooves and are inserted in an overlapping pattern from right to left.
- Membrane sleeve or opening for filling with aerosol for testing the filter of the downflow unit [1] at the left side of the sample chamber and of the exhaust air unit [7] at the right side of the sample chamber.

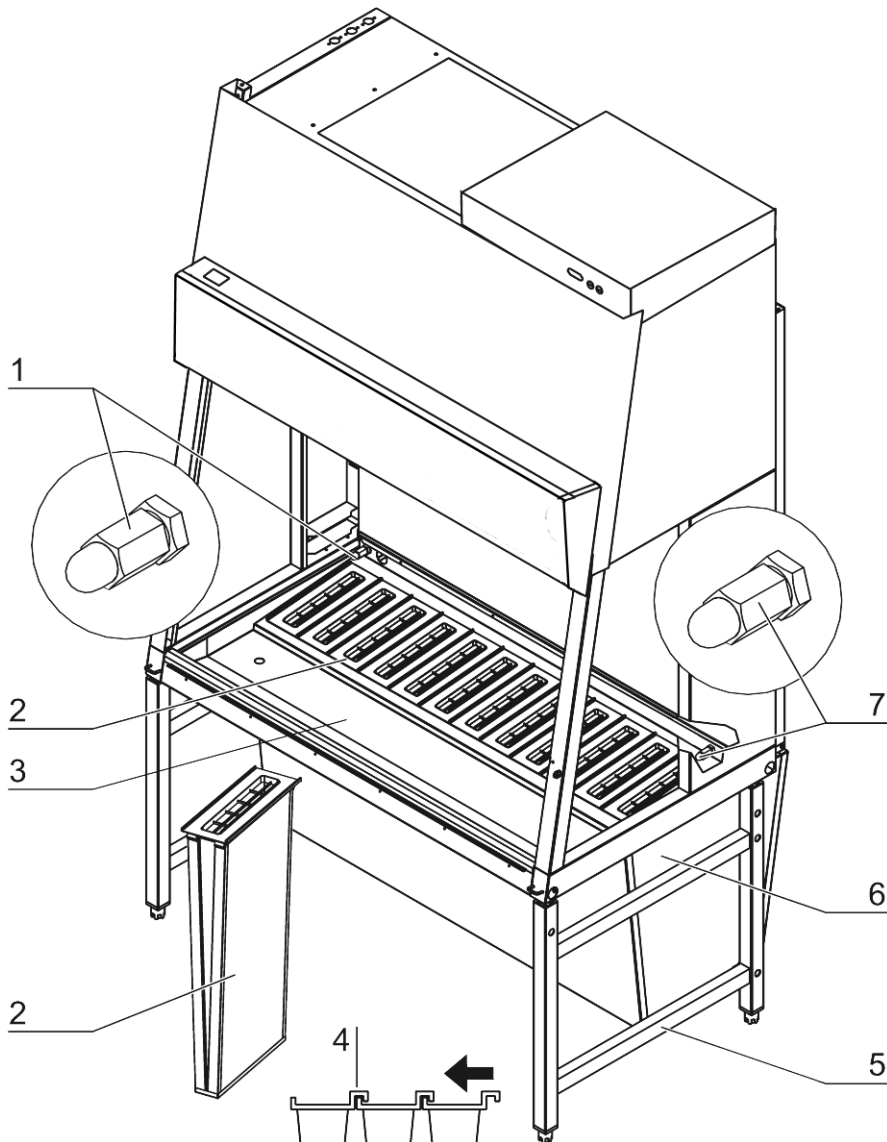

Fig. 3b
Overall view / Model Maxisafe 2020

4. Unit description

4.2 Safety system

The safety system comprises a combination of protective and alarm systems that ensure maximum personal and material protection.

Safety systems:

- **Vacuum-sealed air system**
A vacuum-sealed air system in combination with HEPA filters for downflow and exhaust air forms the basis of the safety system for personal and material protection.
- **Personal protection**
Air aspirated from the exterior along the entire working opening at a constant high velocity prevents that:
 - agents may leak through the working opening of the chamber.
 As the exterior air pressure around the unit exceeds the pressure of the internal air system (vacuum sealing), it is ensured that:
 - agents cannot be released to the exterior in the case of a leak in the cabinet housing.
- **Material protection**
A steady airflow within the air system ensures that:
 - a constant downflow allows the HEPA filters to remove contaminants so that the samples are always surrounded by ultrapure air,
 - harmful particles are not carried over through the sample chamber (protection from cross-contamination).
- **HEPA filters**
The downflow (i.e. the air circulating within the device) and the exhaust air (air that is released to the exterior) are cleaned by HEPA filters (HEPA = High Efficiency Particulate Air Filter).
For version Maxisafe 2020, a prefiltering system is used to increase the filter efficiency and to protect the exhaust air and downflow systems.
- **Safety lockout**
To protect from UV radiation, the optional UV disinfection routine can be run only if the front opening is closed. During UV disinfection, the front opening safety lockout is activated and prevents harmful UV radiation from being emitted from the sample chamber.

Warning system:

- **Airflow monitoring**
Airflow monitoring determines the velocity of the airflow in the sample chamber as well as the inflow velocity of the air aspirated from the exterior through the working opening. As soon as airflow velocities move above or below a specified safety value, a signal is transmitted to the alarm system.
- **Visual and audible alarm system**
The warning system constantly monitors the safety-relevant device functions:
 - Inflow velocity of the air aspirated from the exterior,
 - downflow velocity,
 - working position of the front window.
 If the warning system detects changes to one of these device functions, it issues:
 - an audible and a visual alarm signal.

4. Unit description

- **Position monitoring**
The position sensors monitor the position of the front cover as well as the movement of the front window; it will indicate when the front window is in the working position.
- **Performance Factor**
The Performance Factor (PER) is a value that indicates the safety state of the safety cabinet. This value is calculated from data determined by the safety system and from values captured empirically by service personnel during safety checks. This data is entered into a parameter list of the control software and interconnected. The result can be indicated by the display.

4.3 Filter system

Model Safe 2020:

Fig. 4a: The filter system consists of two HEPA filters [2] and [5] for the circulating air and for the exhaust air and of a coarse filter for the aspirated air.

HEPA filters: Room air [10] is drawn into the sample chamber through the working opening. In the air duct, room air and the downflow within the chamber [7] are then blended to make up the blend air [9]. The blend air is then:

- filtered proportionally by the downflow filter [5] and supplied as ultrapure air [6] evenly into the sample chamber of the device,
- filtered by the exhaust air filter [2] and released as ultrapure air [1] to the exterior of the device.

Inlet air protection: The air duct between the sample chamber and the device plenum has an inlet air protection [8] below the working surface to prevent coarse particles from entering the plenum where they may impair blower [3] and [4] and filter functions.

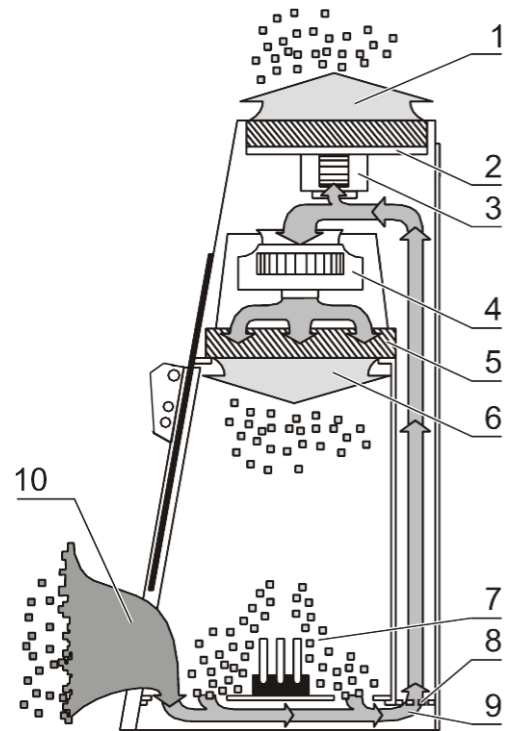

Fig. 4a
Filter system with downflow
filter and exhaust air filter /
model Safe 2020

4. Unit description

Model Maxisafe 2020:

Fig. 4b: The filter system consists of a set of HEPA primary filter [10] (the number of filters depends on the sample chamber width) and two HEPA filters [2] and [5] for downflow air and exhaust air.

HEPA primary filter:

The compact size of the filter inserts allows filter replacement with minimal contamination hazard. The use of the primary filter protects the downflow and exhaust air filters considerably. The filter inserts used are HEPA filters of Class H14 (according to DIN EN 1822). Alternatively, activated carbon filters can be inserted into the housing to protect from smells. Room air [11] is drawn into the sample chamber through the working opening. In the air duct above the prefilter, room air and the downflow within the chamber [7] are then blended to make up the blend air [8]. The blend air is then:

- aspirated into the prefilter [10], filtered and fed into the air duct [9].

HEPA filters: From the air duct, the primary filtered air is:

- filtered proportionally by the downflow filter [5] and supplied as ultrapure air [6] evenly into the sample chamber of the device,
- filtered by the exhaust air filter [2] and released as ultrapure air [1] to the exterior of the device.

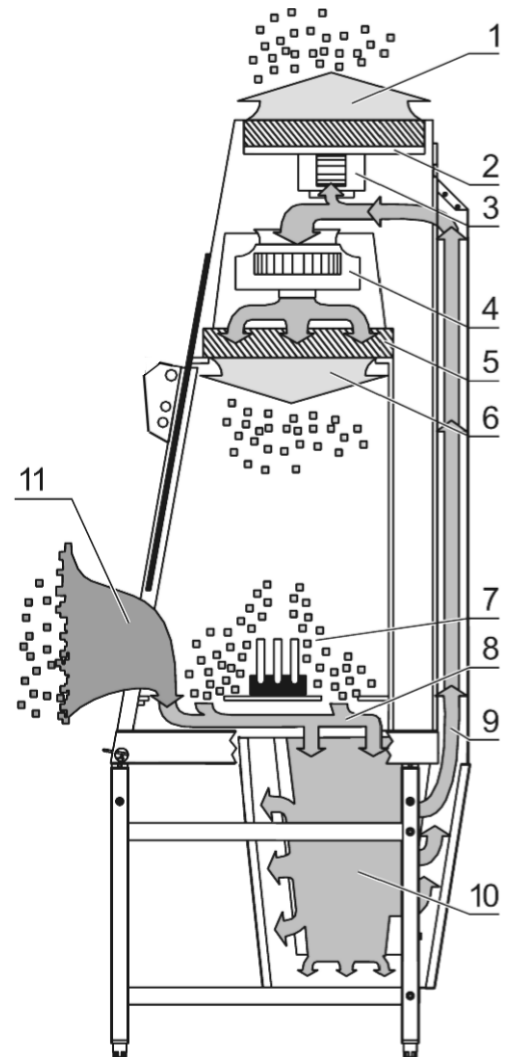

Fig. 4b
Filter system with primary
filter, downflow filter and
exhaust air filter / model
Maxisafe 2020

4. Unit description

4.4 Controls and display

Fig. 5: The safety cabinet is equipped with two separate control elements that operate independently of each other:

- pilot switch [1].
- operating panel [2],

The status indicators of the display [2] indicate control operations initiated with the control elements.

Pilot switch: Use to control all basic functions required for the operation.

Operating panel: The operating panel [2] has a display panel for text or number value output as well as 12 LEDs for visual indication of the current operating state of the device.

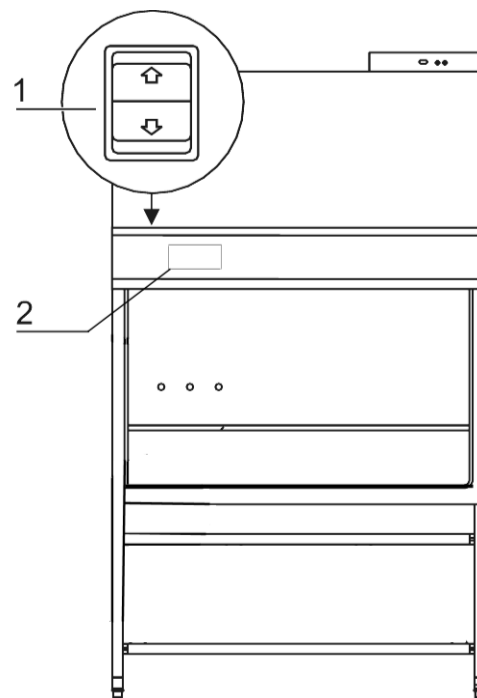

Fig. 5
Controls and indicators

4. Unit description

4.5 Sample chamber access

The sample chamber of the device is accessible via two modes:

Front cover:

Fig. 6a: Manual opening of the front cover [2] allows access to the complete sample chamber width with an opening height **C**. It is generally needed for decontamination and introduction of larger accessories.

 **NOTE – Front cover lockout**

The front cover is equipped with a safety lockout and can only be opened in standby mode, i.e. when the front window is completely closed.

Front window:

Fig. 6b: The electrically operated front window [1] is made of multi-layer safety glass and integral to the front cover frame. It can be raised to a maximum opening height **B** (773 mm). To access the sample chamber during the work process, the front window must stay in the work position with opening height **A** (200 mm).

 **CAUTION – Front window movement!**

Do not attempt to move the front window manually as otherwise the motor drive may be damaged.

Lowering the front window when the device is deenergized:

The safety feature (optional) is backed up by a battery. Should a power failure occur, the pilot switch (see Section 6.4) can be used to lower the front window completely.

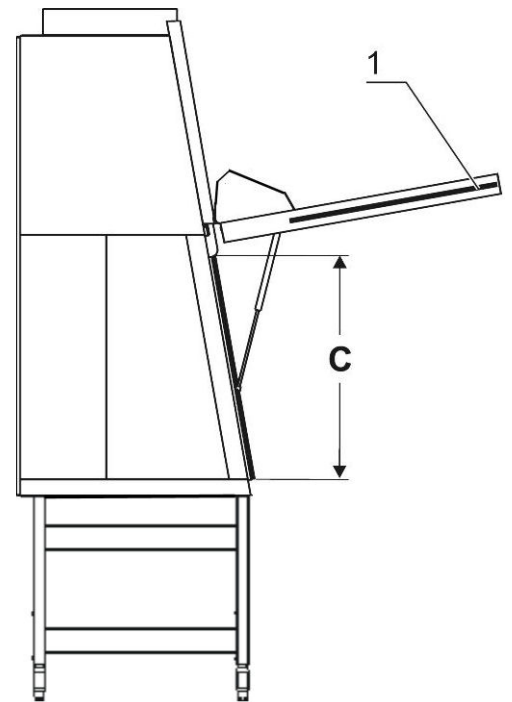

Fig. 6a
Access through front cover

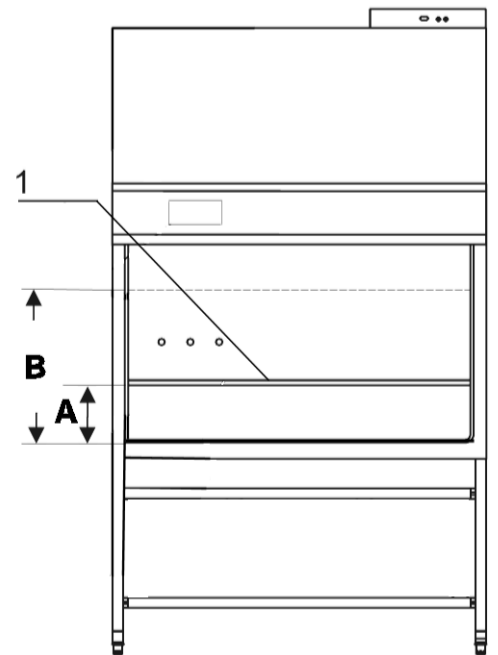

Fig. 6b
Access through front window

4. Unit description

4.6 Device interfaces

Fig. 7a: The standard equipment includes the outlets [10] for internal power supply as well as the openings [8] on both sides for routing of cables and hoses. All other supply connections are available as options.

Power supply connection: The connection to the power supply system is achieved through a cable with grounding plug [2] at the rear of the electrical box.

Contact connection: The front of the box has an RS 232 interface [3] for the connection to a PC as well as two fuse holders for 5A miniature fuses:

[4] for (L),

[5] for (N).

Internal power supply: There are two electrical outlets (5A) [10] and one UV disinfection adapter (optional) [9] located in the side walls.

Media valves: There are two sealed feed throughs [8] on each side. These may be used for installation of media valves [7].

Media supply lines: Additionally, media can be supplied into the sample chamber through three pipes. The inlets [1] are located on top of the housing, the outlets [6] are placed at the sample chamber backpanel.

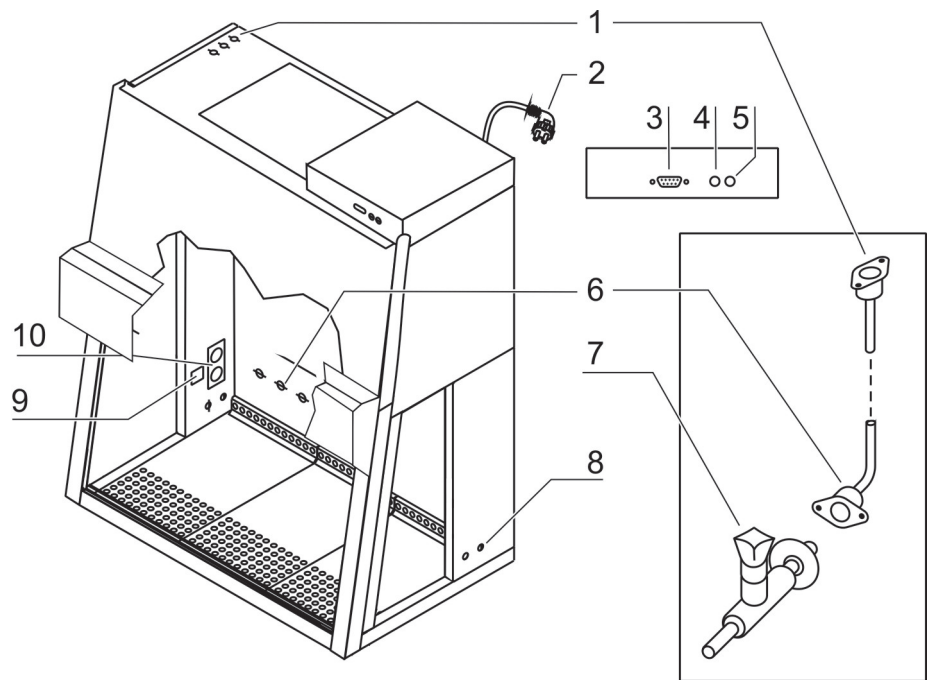

Fig. 7a
Supply interfaces

4. Unit description

Disinfection adapter (optional), Fig. 7a: The disinfection adapter [9] is used to connect a mobile UV radiation device. The adapter is connected to the device control, the UV disinfection routine with a mobile UV device may be controlled with the remote control.

Media connections (optional): The media supply unit consists of three pipes that are routed into the sample chamber through the top of the unit. The inlet connections [1] and outlet connections [6] with thread (R 3/8"), e.g. for media valves [7], are preinstalled and equipped with a sealing plug. The media connections are universal-type connections. Two equipotential bonding connections are installed at the top of the unit and at the stand.



Caution – Combustible gas!

If a gas burner is to be operated in the sample chamber, an appropriate shut-off device for the gas supply system (shut-off valve, solenoid valve) must be installed. Use only laboratory safety burners in the sample chamber.

External systems: A failure detection systems or gas supply solenoid valves may be connected to the safety cabinet control. The unit may also be connected to an external ventilation system.

4.7 Sample chamber illumination

Fig. 7b: The work space illumination [2] is equipped with two fluorescent tubes that are installed behind the light dome [3].

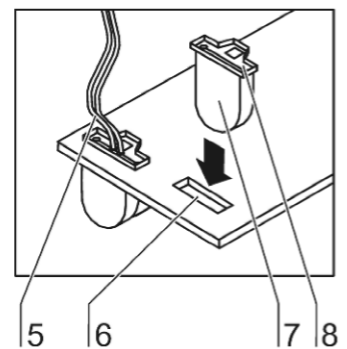
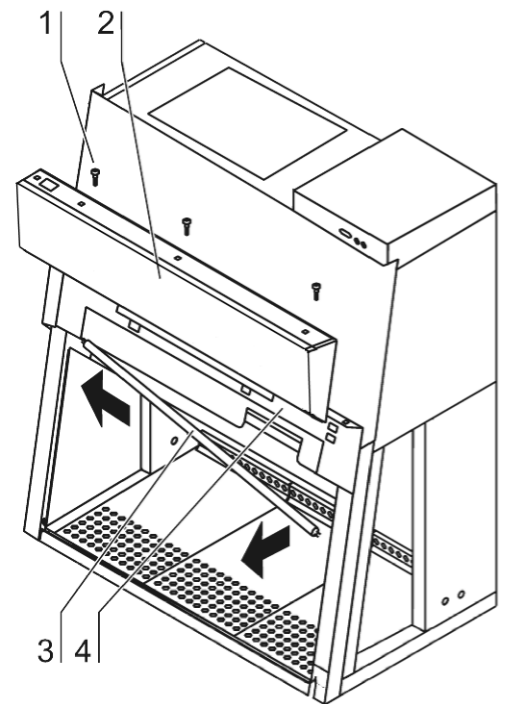

Fig. 7b
Sample chamber illumination

4. Unit description

4.8 UV lamp unit

Fig. 8: The UV lamp unit consists of two lamp housings [2] with two UV lamps each [1] that are integral to the side walls. Both lamp housings are protected by a stainless steel cover [3].
By cross-radiation of the UV units, all surfaces will be disinfected as the shadow zone is reduced.
The operating time of the UV lamps is preset.

 **NOTE – Protection from UV radiation**

As a protection from harmful UV radiation, the UV lamps can only be activated if the front window is completely closed.

4.9 Working area

The standard equipment comprises the segmented workplate for the Safe 2020 and the single-piece workplate for the Maxisafe. Special workplates are available as optional accessories. The workplates or workplate segments are placed onto the frame above the sample chamber floorpan using two submerging wire straps as handles.

Fig. 9: The working area **A** for perfect material protection extends over the entire width **B** and depth **C** of the workplate. The two arm rests [3] are positioned at a distance **D** (20 cm) to each other centrally on the workplate [1] or on the workplate segments. The armrests are installed to the second perforation line [2] of the workplate.

 **NOTE – Spilling liquid**

Liquid spilled within the safety cabinet can penetrate the filters through the slots. If this occurs the user must have the safe function of the filters checked by a qualified service technician.

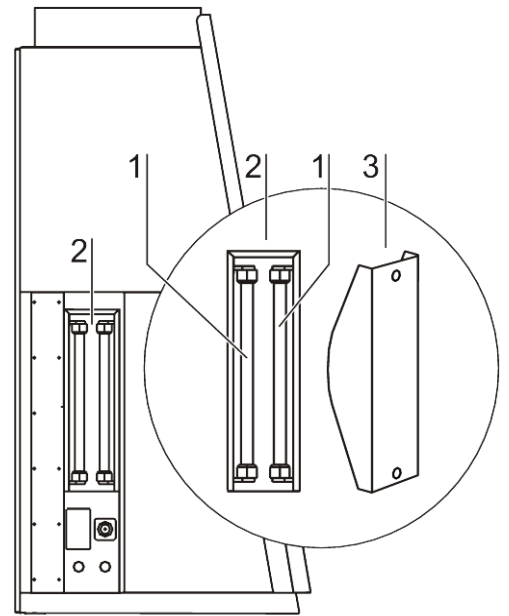

Fig. 8
UV lamp unit

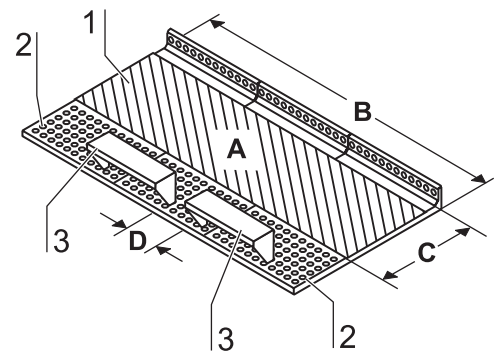

Fig. 9
Working area on the workplate, armrests

5.

Start-up

5.1 Initial operation

Prior to initial operation, the safety cabinet must be subjected to an installation test. Correct assembly and installation performed by the operator are essential for good start-up.

Model Maxisafe 2020:

Upon the initial connection to the power supply system, the device control of version Maxisafe 2020 starts an automatic calibration routine to determine the parameters for the safety system of the device.



NOTE – Calibration routine

The calibration routine is no substitute for the installation check performed by the service personnel.

5.2 Installing unit and accessories

Model Safe 2020:

Device without stand:

- Place the device without stand onto a sufficiently stable substructure so that the weight of the device frame does not rest upon the floorpan.
- Remove the protective foil from the floorpan.

Device with stand:

To assemble the (optional) stand and to install the device frame to the stand:

1. **Fig. 10a:** Slide the two crossmembers [2] onto the retaining angles [3] of the sidemembers [1]. Secure the crossmembers to the two sidemembers using the screws [4].
2. To attach the device frame [5] to the stand [7], install four Allen screws [6] loosely into the corresponding threaded holes at the underside of the device.
3. Place the safety cabinet [1] onto the stand so that the Allen screws [6] pass through the corresponding holes [8] of the retaining tabs [10].
4. Push the device frame [5] in the grooves [9] of the retaining tabs [10] all the way to the stop.
5. Tighten the four Allen screws [6].

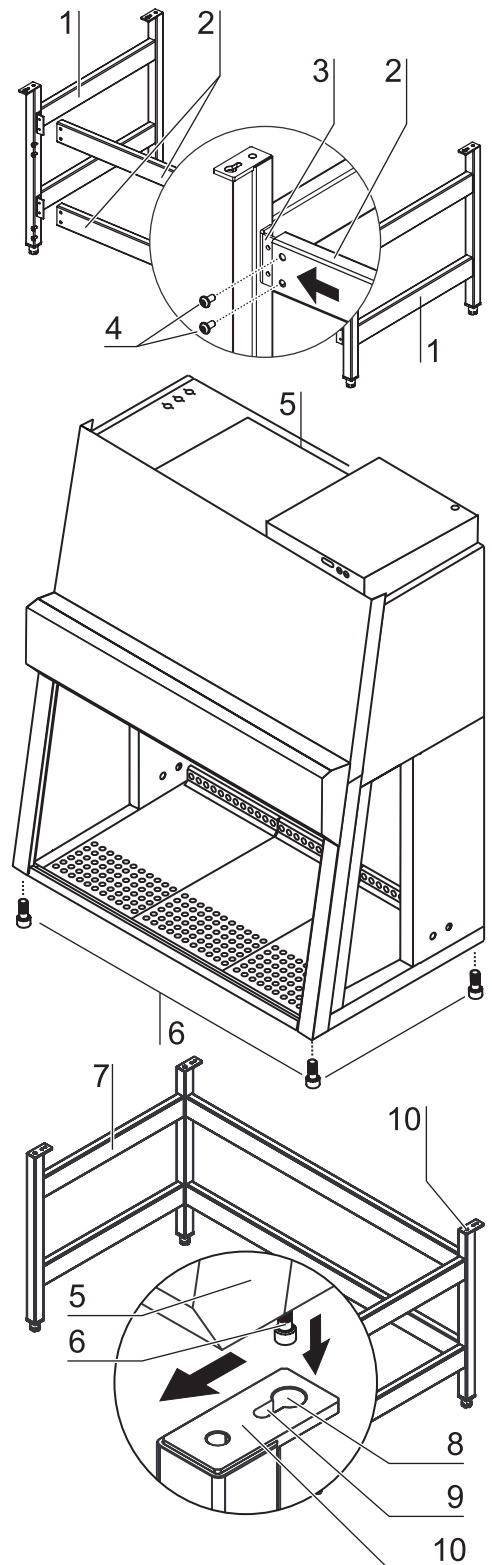

Fig. 10a
Stand installation model
Safe 2020

5. Start-up

Model Maxisafe 2020:

Fig. 10b: The stand [3] and the prefilter housing form an assembly. To facilitate the installation of the device frame [1], the stand is equipped with a lifting mechanism. The four columns [7] of the stand have threaded rods [6] onto which the device frame can be placed and lowered.

1. **Fig. 10b:** Unscrew the threaded rods from their hex disks [5] by approx. 10 cm and make sure their height is identical on all four columns.
2. Place the safety cabinet onto the threaded rods. Check to see whether each guide pin [4] is seated perfectly in its receptacle at the lower device frame.
3. Screw in each threaded rod at its column in short, even intervals all the way to the stop of the hex disk.

 **NOTE – Leveling the device**

To level the device, do not use the lifting mechanism but only the adjustable stands of the device.

4. Align the working area of the safety cabinet:
Place a bubble level onto the workplate and rotate the stands [2] of the stand using a 24-mm wrench until the workplate is exactly horizontal in all directions. For the vertical alignment of the device stands, proceed from left to right and from rear to front.

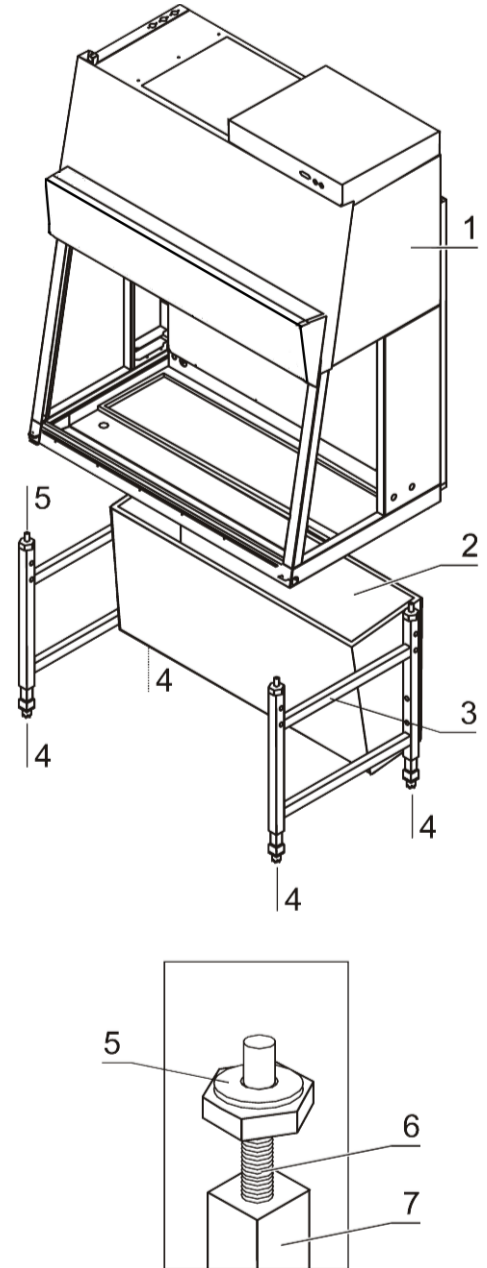

Fig. 10b
Stand installation model
Maxisafe 2020

5.

Start-up

Drain valve (optional)

Fig. 10c: The drain valve [2] is installed into the floorpan opening [1] at the floor at the left front area of the sample chamber.



NOTE – Installation

The optional drain valve must be installed only by authorized service personnel.



WARNING – Drain valve lock!

To prevent contaminated liquid from being accidentally drained from the floorpan, the drain valve must be secured using a conventional padlock.

5.3 Levelling the cabinet

The cabinet should be levelled only after it has been positioned.

1. Remove transport protection (foil) from the workplate or from the workplate segments.
2. Lift the workplate or the workplate segments by the wire hooks and place it/them onto the front and rear rails in the sample chamber with the wide line of holes facing forward.
3. Device without stand: Place a bubble level onto the workplate and align the substructure until the bubble level indicates an exactly horizontal position in all directions.
4. Device with stand: Place a bubble level onto the workplate and use the four levellers of the stand to effect a level state in all planes.

When adjusting the device stand height, proceed from right to left and from rear to front.

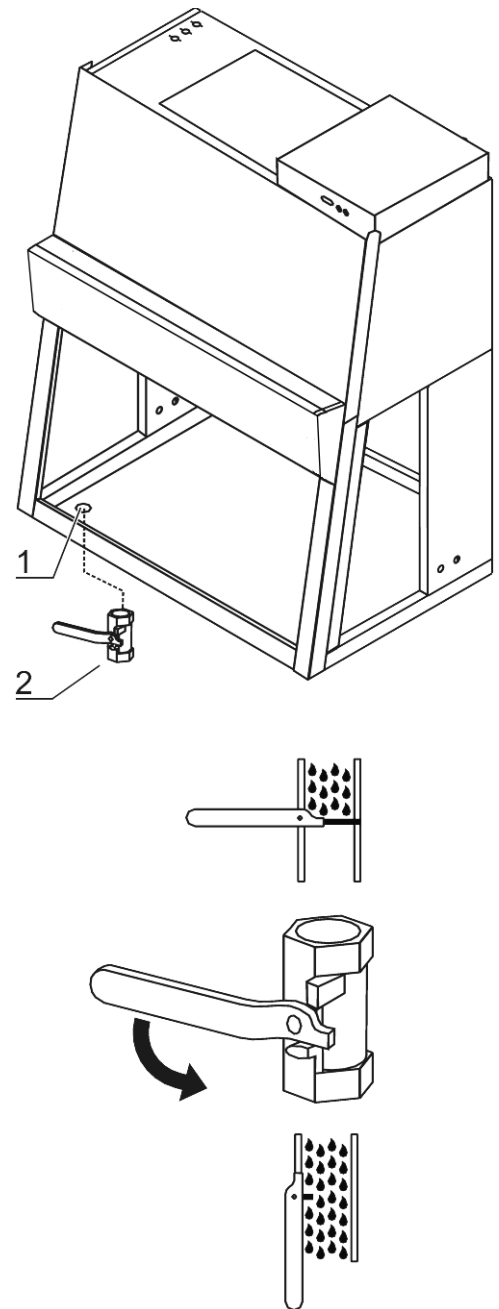

Fig. 10c
Drain valve installation

5.

Start-up

5.4 Power supply connection



WARNING – High voltage!



Contact with current-carrying components may cause a lethal electric shock.

Before connecting the device to the power supply system, check plug and power supply cable for possible damage.

Do not use damaged components to connect the device to the power supply system!

Establishing the power supply connection:

1. Before connecting the device to the power supply system, check to see if the voltage of the outlet corresponds with the specifications on the nameplate of the device. If the ratings given for voltage (V) and maximum current (A) are not correct, the device must not be connected to the power supply system.
2. Connect the grounding plug of the device to a properly grounded and fused outlet.
 - The outlet must be fused separately using a fusible link T 16 A or using a circuit breaker B 16.
3. Make sure that the power cable is routed away from the counterweight and cable guide. For this purpose, the power cable can be secured to the device ceiling using the enclosed adhesive bases and cable ties (see installation instructions).
4. Make sure that the power supply line is not subjected to tensile or compressive force.

Installation of the power supply connection:

To protect against accidental switch-off, the outlets for the connection to the power supply must be located outside the normal hand reaching range and must be accessible only to authorized personnel. Ideally, the outlets should be installed above the safety cabinet.

Connecting the equipotential bonding:

If the sample chamber is supplied with media (gas, water, etc.), the on-site equipotential bonding must be connected to one of the premounted threaded bushings either at the top of the housing or at the stand.

Initialization routine:

After the unit has been connected to the power supply system, the device control runs through a start-up initialization routine and switches the functions to the OFF mode. The safety cabinet is now operational and can be operated using the remote control or the pilot switch

Presetting the alarm limits upon initial operation, Maxisafe 2020:



NOTE – Presetting the alarm limits

The alarm limits must be set only upon the initial operation of the device.

5.**Start-up**

After the initialization routine has been completed, the calibration routine is run (only Maxisafe 2020):

- The display shows "CAL".
- The routine starts automatically when the device control is in the work mode (see Section 6.2) and runs for approx 30 minutes. If the airflow is disturbed during the run time, the routine is cancelled and restarted automatically.
- At the end of the routine, the determined parameters for the alarm limits are saved.

**NOTE – Initial operation**

According to applicable national standards and regulations, the calibration routine is no substitute for a start-up performed by an authorized service technician.

Setting the clock:

After the initialization routine has been run, the clock should be set to the appropriate time zone (see Section 6, Operation).

**NOTE – Power supply connection**

The safety cabinet should remain connected to the power supply system at all times to ensure that settings for the individual unit configuration remain active in the memory. If the power supply is interrupted for more than 5 minutes, the time must be reset correctly. After the power supply connection has been reestablished, the system switches to the operating mode that had been active last.

5. Start-up

5.5 RS 232 interface connection

The RS 232 interface has been designed for a cable connection with 9-pin connectors and a contact assignment of 1:1.

Connection of the device:

1. Turn PC off.
2. **Fig. 11:** Connect the connector of the serial interface cable (not comprised in the scope of delivery) to the socket [1] at the supply interface at the front of the electrical box.
3. Connect the serial interface cable to an unassigned slot COM 1/COM 2 etc. at the PC.
4. Turn PC on.

Transfer protocol:

The interface must be configured as follows:

Baud:	9600
Data bits:	8
Parity:	none
Stop bit:	1
Protocol:	none
FIFO-puffer(extended modulation):	enabled

Occupancy of conductors:

- Type of connector [X] : 9-Pin SUB-D
- Pin 2: TxD
- Pin 3: RxD
- Pin 5: GND

5.6 UV connection

Fig. 12: UV disinfection adapter (optional) for an external UV disinfection unit.

Voltage:	230 V
Current:	max. 1,1 A
Connectors:	[1], [2], [3] and PE-sign

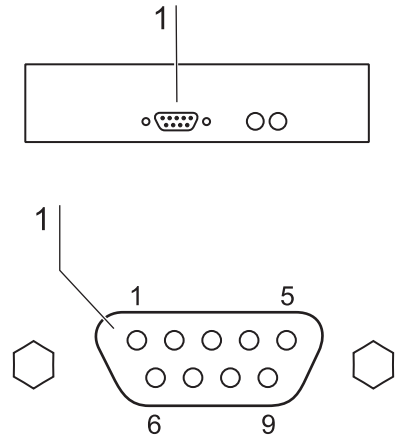

Fig. 11
RS 232 interface connection

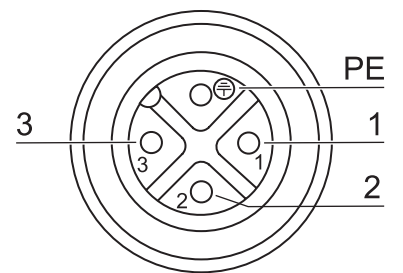

Fig. 12
UV connection

5.**Start-up****5.7 Installation test**

Do not operate the device before the installation test has been completed.

- The installation inspection of the device must be conducted in accordance with EN 12469 and additionally according to DIN 12980 for Maxisafe 2020. The cabinet may be operated as a Class II microbiological safety cabinet, in accordance with EN 12469 / 2000, if the device functions or function patterns listed below were checked and if the test results are within the safety value tolerances specified in Annex F:
 - Electrical safety test
 - Inflow velocity test
 - Downflow velocity test
 - Leakage test of HEPA filters
 - Airflow control test
- A repeat test must also be performed after repairs to the device or after major changes (more than 5 cm) to the location of the device.
- The operator must prepare a test report or request a written test report from the authorized test service.

**NOTE – Safety warranty**

The operational safety of the device, particularly the personal and material protection, are guaranteed only if all safety functions of the device have been tested and approved.

Thermo Electron LED GmbH will not warrant the operational safety if the device is operated without performance of the required installation test or if the installation test and repeat test are not performed by adequately trained and authorized personnel!

**NOTE – Device hygiene**

The initial start-up with subsequent installation test does not include any decontamination measures. For operation in the work process, the sample chamber of the device and the accessories required for the work process must be disinfected and cleaned in accordance with the hygiene guidelines set forth for the application.

6. Handling and control

6.1 Display

Fig. 13: The display in the light dome is used as indicator and output instrument for:

- status messages,
- parameter input and output.

6.1.1 Functions of the display components

[1] Display segment for numbers and text

Value displays

The LEDs 2-5 illuminate when the corresponding value is called up:

- [2] Display time (yellow LED), usually the active standard display
- [3] Display downflow velocity (yellow LED)
- [4] Operating hours after last filter replacement (yellow LED)
- [5] Display Performance Factor (yellow LED)

Keys

- [6] Potential-free contact for solenoid
- [7] Set time
- [8] Move window up
- [9] Switch internal outlet on/off (the LED [17] indicates that voltage is applied)
- [10] Move window down
- [11] Switch UV disinfection on/off (the yellow LED indicates that the UV disinfection routine has been activated; if the optional UV lamp is not installed, the function of this key is disabled).
- [12] Switch device on/off (switch-off only in stand-by mode, see Chapter 6.3)
- [13] Toggle display: Time, downflow velocity, operating hours, performance factor
- [14] Switch work space illumination on/off

Function displays

The LEDs 15 - 18 illuminate only when the corresponding value is called up:

- [15] Ventilation reduced (yellow LED)
- [16] Potential-free contact activated (yellow LED)
- [17] Internal power supply activated (yellow LED)
- [18] UV disinfection routine activated (yellow LED)

Status displays

The LEDs 19/20 and 21/22 show the operating condition of the device as either/or conditions:

- [19] Front window **is not** in working position (red LED)
- [20] Front window **is** in working position (green LED)
- [21] Airflow **is not** steady (red LED)
- [22] Airflow **is** steady (green LED)

6. Handling and control

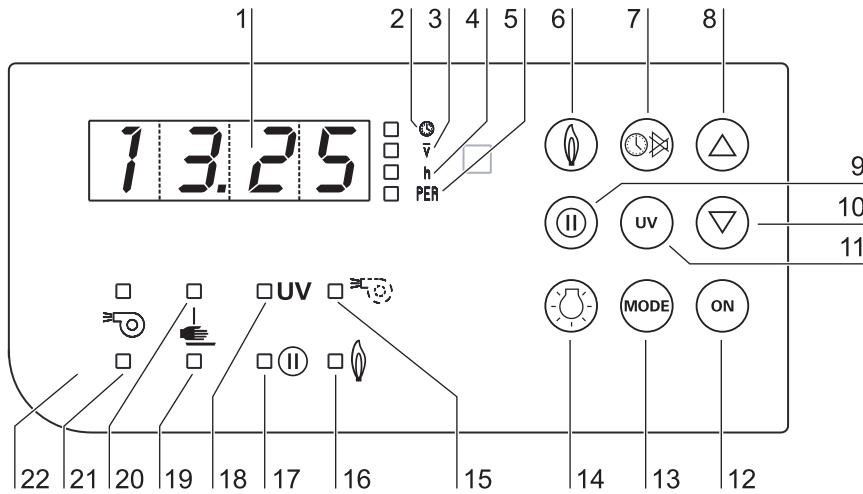

Fig. 13
Indicator and operating panel

6.1.2 Display during the calibration routine

The routine runs for approx 30 minutes. During this time, the display shows alternatingly **cal** and the descending time value. If the calibration routine cannot be started due to faults, the display shows **cal** permanently.

6.1.3 Display in OFF mode

In the OFF mode, the display shows the current time.
For the initial start-up of the device, the clock must be set to the correct time zone and to the corresponding time output (CET mode or AM/PM mode) (see Section 6.3.9).

6.1.4 Display in work mode

In the work mode, the display shows the values of the device data that had been shown last (see Section 6.3.9.ff):

- Time (hours and minutes)
- Downflow velocity
- Operating hours after last filter replacement
- Performance Factor

6.1.5 Power interruption

If the master PCB of the device detects a power failure or a failure of the power supply, a warning is issued.

Note – Power failure warning

In case of a power failure, the display goes off after 10 seconds, then an audible alarm signal sounds for about 30 seconds. After this warning, the device is no longer operative.

6. Handling and control

The battery operation safety feature (optional) allows the complete lowering of the front window after a power failure by pressing the pilot switch.

6.1.6 Display and functions after a power failure

After the power supply has been reestablished after a power failure, the display shows the values and functions that were last shown prior to the failure.

The functions that had been selected last will be continued where they had been interrupted.

6.1.7 Failure messages

Failure messages are shown on the display as text/number combinations with the codes ER 1 to ER 5. If one of these codes appears on the display, contact Technical Service immediately.

Error code	Fault cause
ER 1	Pressure sensor 1 / supply
ER 2	Pressure sensor 2 / exhaust
ER 4	BUS error
ER 5	RAM error

6. Handling and control

6.2 Description of the operating modes

The following operating modes exist for the device:

- **Calibration mode (after initial start-up, version Maxisafe 2020)**
- **OFF mode**
- **Work mode**
- **Standby mode**
- **UV mode**

OFF mode: The device is at "idle". Utilized for charging the sample chamber or for cleaning and disinfection, the front cover can be opened when the front window is completely closed.

- The air system blowers are switched off.
- The sample chamber illumination is available.
- The internal power supply within the sample chamber is available:
 - If the internal power supply is activated, the yellow status indicator **INTERNAL POWER SUPPLY ACTIVATED** is illuminated.
- The display shows the time. If the timer has been activated, the display alternately shows the current time and the preset switching time for the timer.
- The contact for the external device connection is **not** available.

Work mode: Ensures personal and material protection. In this operating mode, the work process is run within the sample chamber. The device is in the work mode when the front window has been moved into the working position and the airflow is steady.

- The front window is in the working position:
 - The green status indicator **FRONT WINDOW IS IN WORKING POSITION** is illuminated.
 - No audible alarm signal.
- The air system blowers are switched on to ensure steady airflow:
 - The green status indicator **AIRFLOW STEADY** is illuminated.
- The sample chamber illumination is available.
- The power supply for the sample chamber outlets is available:
 - If the internal power supply is ON, the yellow status indicator **INTERNAL POWER SUPPLY ACTIVATED** is illuminated.
- The monitor-contact for the external device connection is available:
 - If the contact is activated, the yellow status indicator **POTENTIAL-FREE CONTACT ACTIVATED** is illuminated.
- The display can show values for: Operating hours, downflow velocity, and exhaust airflow velocity.

Window open mode: Designates the condition when the window is open and located outside the working position. To install and remove accessories, the front window can be opened or moved upwards.

- The airflow system blowers are switched on:
 - The red status indicator **AIRFLOW STEADY** is illuminated.
- The front window is not in the working position:
 - The red status indicator **FRONT WINDOW NOT IN WORKING POSITION** is illuminated.
- The work space illumination is operational.

6. Handling and control

- The internal power supply is operational:
 - If the internal power supply is switched on, the status indicator **INTERNAL POWER SUPPLY ACTIVATED** illuminates.

Standby mode: For an interruption of the work process, the front window can be lowered and the sample chamber sealed aerosol-tight. The air system output has been reduced to match the lower air requirement.

- The front window is closed:
 - The air system operates at reduced output.
 - The red status indicator **FRONT WINDOW IS NOT IN WORKING POSITION** is illuminated.
 - The yellow status indicator **AIRFLOW REDUCED** is illuminated.
- The sample chamber illumination is available.
- The internal power supply in the sample chamber is available:
 - If the internal power supply is ON, the yellow status indicator **INTERNAL POWER SUPPLY ACTIVATED** is illuminated.

UV mode: For running the UV disinfection routine, the front window is completely lowered to protect against UV radiation. The routine cannot be run until the front window is in the "closed" position.

- The UV disinfection routine is activated:
 - The yellow status indicator **UV DISINFECTION ROUTINE ACTIVATED** is illuminated until the preset time for the routine has elapsed. Then, the UV lamps are switched off automatically, and the status indicator is switched off.
- The sample chamber illumination is available.
- The internal power supply in the sample chamber is **not** available.
- The integral UV lamp (optional) is available.
- The power supply for the UV disinfection adapter (optional) is available.

6. Handling and control

6.3 Operation system

The device control software automatically determines the temporary operating state of the safety cabinet and automatically disables those functions of the operating panel that are in contradiction to the safety requirements of the switching state. The keyboard has master priority over the pilot switch.

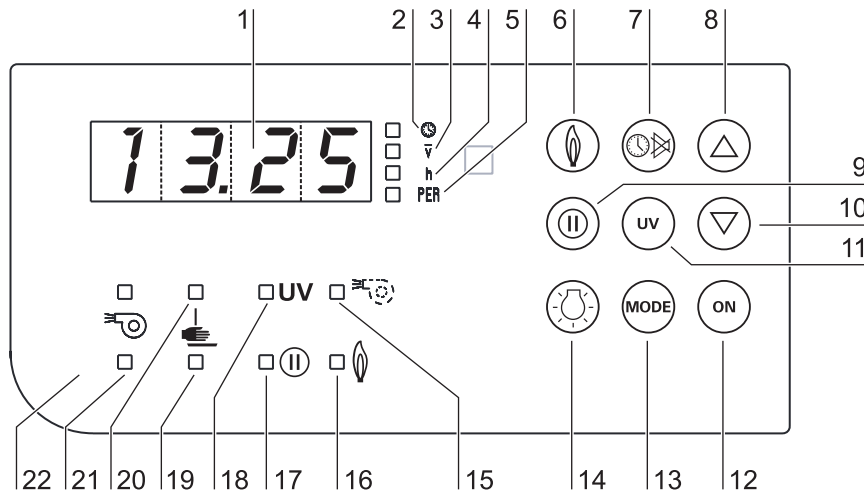

Fig14
Indicator and operating panel

6.3.1 Basic functions

Fig.14: The easy operator guidance ensures that all basic functions can be controlled with only a few operating steps and that the safety cabinet can be shifted into the working mode.

► Switching the device into work mode:

- Keep the  key depressed until the ready signal sounds

► Moving the front window up:

- Press the  key for approx. 1 second

When the front window reaches the working position, the movement stops automatically. When the movement starts above the working position, the front window stops at the maximal opening position.

► Stopping the upward movement:

- Press, then release the  key

This function can be selected with any key except

the  key.

6. Handling and control

► **Lowering the front window:**

- Keep the  key depressed









► **Stopping the downward movement:**

- Release the  key

► **Switching the device to OFF mode:**

- Keep the  key depressed until the ready signal sounds



Availability of functions in the different operating modes: x = available

Key	Mode			
	OFF mode	Work mode	Standby mode	UV mode
	X	X	X	X
		X	X	
		X	X	
	X	X	X	
	X	X	X	X
		X	X	X
	X	X	X	X
	X	X		
		X		

6. Handling and control

6.3.2 Moving the front window to the working position

1. Raising or lowering the front window:

- Press, then release the  key for approx. 1 second
- The red status indicator  on the display is illuminated
- The audible alarm signal is on.

2. When the front window reaches the working position, the movement is automatically stopped.

- The green status indicator  on the display is illuminated
- The audible alarm signal is off if the airflow is steady.

3. If the movement starts above the working position, the front window must first be lowered below the working position and then be raised again. To lower the front window:

- Keep the  key depressed

4. To stop the downward movement:

- Release the  key

6.3.3 Silencing the audible alarm signal

When the front window is moved out of the working position or when the pressure sensors detect a safety-relevant change of the airflow velocities, the corresponding visual and audible alarm signals are issued. The alarm remains active until the front window has been moved to the correct working position or until the airflow velocity corresponds with the preset values.



CAUTION – Unsafe working!

When the alarm signals are activated, safe working is no longer ensured.



NOTE – Switching the alarm signals off

If the alarm signals fail to be switched off automatically, move the front window to the uppermost or lowest position and contact the Technical Service.

6. Handling and control

6.3.4 Switching the illumination on and off

In each operating mode, the sample chamber illumination can be switched on or off.

- To switch the illumination on or off:

Press, then release the  key

6.3.5 Activating and deactivating the internal power supply

All outlets in the sample chamber can be activated (power supply on) or deactivated (power supply off) simultaneously.

1. To activate the power supply:

Press, then release the  key

The yellow status indicator  is illuminated.

2. To deactivate the power supply:

Press, then release the  key

The yellow status indicator  goes off.

6.3.6 Displaying the UV disinfection time

This value refers to the operating hours of the set run time of the UV disinfection or of the power supply for the UV disinfection adapter (optional). This display function is only available when the front window is not closed. The device must be switched to work mode.

1. To display the value:

- Press, then release the  key

The time value is output in segments of 30 minutes.

2. To deactivate the value display:

The value display is deactivated automatically after 2-3 seconds.

6.3.7 Activating and deactivating the potential-free contact (optional)

An external solenoid valve or alarm system that is connected to the safety cabinet control system can generally be enabled only if the device is operated in the secure work mode. Enable or disable an external system:

1. To activate the contact:

Press, then release the  key

The yellow status display  is illuminated.

6. Handling and control

2. To deactivate the contact:

Press, then release the  key

The yellow status display  goes off.

 **NOTE – LED for potential-free contact**

**If this button is pressed on the operating panel,
the LED also illuminates if no external alarm
system is connected to the device.**

6.3.8 Switching the cabinet to OFF mode

The unit can be switched to OFF mode from any other operating mode:

- Keep the  key depressed until the ready signal sounds

6.3.9 Setting the time

The current time of the time zone in which the unit operates must be set at the start-up of the safety cabinet. Two different display modes can be selected:

- CET mode (24:00 hours)
- AM/PM mode (12:00 hours)



When the time is to be set, the device must be in the OFF mode.

1. Set the time:

Keep the  key depressed until the two-digit hour display flashes.

The minute display shows either A, P or no value (CET time display).
The time zone is set at the same time as the hour value: First, set
the time zone (sequence: CET, A, P), then set the exact hour value.

2. While increasing or decreasing the hour value in increments, set the
time zone:

Press, then release the  or the  key

3. Scroll through values:

Keep the  or the  key depressed

If the keys are depressed for approx. 2 or 3 seconds, a higher scroll
speed is selected.

4. Store the hour and time zone setting:

Press the  key

The function switches to minute display (flashing).

6. Handling and control

5. Set the minutes:

Press, then release the  or the  key

6. Scroll through values:

Keep the  or the  key depressed

If the keys are depressed for approx. 2 or 3 seconds, a higher scroll speed is selected.

7. Store the minute value:

Press, then release the  key

The display shows the time.

NOTE – Calling up device data

The following data can be called up in succession:

- Time (hours/minutes)
- Downflow velocity
- Operating hours after last filter replacement
- Performance Faktor

To call up values in succession:

- Press, then release the  key for each value

The following three sections contain detailed information about displaying values.

6.3.10 Displaying the downflow velocity

The sensor system of the device continuously monitors the downflow velocity of the airstream in the sample chamber. The currently determined value (m/s) can only be called up in the work mode.

- To display the velocity value:

Press the  key repeatedly until the yellow E LED illuminates.

6. Handling and control

6.3.11 Displaying the operating hours of the HEPA filters

The filter total operating hours after the last filter replacement can be displayed. Upon each filter replacement, the hours are reset to zero.

1. To display the total operating hours:

Press the  key repeatedly, until the yellow status indicator h on the display is illuminated.

2. The value indicates the full hours.

6.3.12 Displaying the Performance Factor

The Performance Factor (PER) is a value that indicates the safety state of the safety cabinet.

This value is calculated from data determined by the cabinet safety system and from values captured empirically by service personnel during safety checks. This data is entered into a parameter list of the control software and interconnected. The result can be indicated by the display.

1. To call up the PER:

Press the  key repeatedly until the yellow status indicator PER on the display is illuminated.

The PER is displayed as an integer.

2. To evaluate the PER:

Number in the 100 to 60 range: The safety cabinet is operationally safe. Personal and material protection is ensured.

Number in the 59 to 30 range: The safety cabinet is still operationally safe. Personal and material protection is ensured. The safety system should be checked.

Number in the 29 to 0 range: The safety of the device may be impaired. The failure causes must only be repaired by authorized service personnel. Contact Technical Service.



NOTE – Calling up value

The value should only be called up, when the airflows have stabilized itself after a lead time of approx. 20 min.

6. Handling and control

6.3.13 Setting and activating the timer

The timer function allows you to switch the safety cabinet from the OFF mode to the work mode at a predetermined time. The timer can only be set when the device is in the OFF mode.

1. To set the switching time:



Keep the  key depressed until the ready signal sounds

The display flashes the two-digit hour display.

2. Increase or decrease the hour value in increments:

Press, then release the  or the  key

3. Scroll through the value display:

Keep the  or the  depressed

If the keys are depressed for approx. 2 or 3 seconds, the higher scroll speed is selected.

4. Store the hour setting:



Press, then release the  key

The function switches to minute display (flashing).

5. Set the minute value:

Press, then release the  or the  key



6. Scroll through the value display:

Keep the  or the  depressed

If the keys are depressed for approx. 2 or 3 seconds, the higher scroll speed is selected.

7. Store the minute value and activate the timer:

Press, then release the  key

The status display   flashes. After a moment, the display shows the current time again. When the value is stored, the timer is automatically activated.

If the setting is not stored, the switching time will be reset to the original value after approx. 15 seconds.

6. Handling and control

 **NOTE – Activating the timer**

If the timer is to be activated without a prior change of the time values, the procedure above is performed and the existing time values are confirmed:

Press, then release the  key for each value.

After the minute value has been confirmed, the timer has been activated.

 **NOTE – Timer function**

The timer can not be used as a start routine that calls up its function automatically. It must be reactivated separately for each deferred device start.



6.3.14 Deactivating the timer

If the device was started at a preset time, the timer function is also deactivated automatically. The deferred start can therefore be cancelled only while the device is still in the OFF mode.

- To deactivate the timer function for starting the device:

Keep the  key depressed until the ready signal sounds

The safety cabinet changes to the work mode.

The status indicator   illuminates continuously, and the display shows the current time.

6. Handling and control

6.3.15 Setting the UV disinfection time

Depending on the equipment option of the cabinet, this setting is used to:



- determine the disinfection time of the optional UV lamps in the side walls or
 - set the time for the power supply of a mobile UV device at the UV adapter.
- Factory setting is one hour. The time can be set within a range between 0 and 24 hours in increments of 30 minutes each. The unit must be in the work mode (the front window must not be closed). For each following start of the UV disinfection, the routine is run with this preset time value.

1. Select the function:

Keep the  key depressed until the ready signal sounds

The display flashes the run time that had been selected last.

2. Set or change the disinfection time. To increase the value in increments:

Press, then release the  or the  key

3. Scroll through the value display in increments of 30 minutes:

Keep the  or the  key depressed

4. Store the setting:

Press, then release the  key

If the setting is not stored, the disinfection time will be reset to the original value after approx. 15 seconds.

6.3.16 Starting the UV disinfection

The UV disinfection can only be started if the front window is completely lowered (standby mode). Depending on the equipment of the unit version, this function is used to:

- switch on the optional UV lamps in the side walls or
- activate the power supply for the outlets of the mobile UV device.
- Start the routine:

Keep the  key depressed until the ready signal sounds

The display alternately shows the Text UV and the remaining disinfection time in hours and minutes.



The yellow status indicator  **UV** is illuminated.

After the disinfection time has elapsed, the current time is displayed.

6. Handling and control











6.3.17 Cancelling the UV disinfection

While the UV disinfection routine is run, it can be interrupted at any time.

1. Cancelling the routine:
 - Press, then release the  key
The status indicator  **UV** goes off.
2. The display shows the current time.

6.3.18 Activating the stop watch

The stop watch function starts a countdown for a preset time (max. 99 min and 59 s) and issues an audible signal when the set time has elapsed. The signal cannot sound if some other device function has already caused an alarm. The function can only be activated if the device is in the normal working mode.

1. Select the stop watch function:
Keep the  key depressed until the ready signal sounds
2. Set the minutes (0 - 99) in increments:
Press, then release the  or the  key
3. Scroll through the value display:
Keep the  or the  depressed
If the keys are depressed for approx. 2 or 3 seconds, the higher scroll speed is selected.
4. Store the minute setting:
Press, then release the  key
The function switches to second display (flashing).
5. Set the second value (0 - 59):
Press, then release the  or the  key
6. Scroll through the value display:
Keep the  or the  depressed
If the keys are depressed for approx. 2 or 3 seconds, the higher scroll speed is selected.
7. Store the setting and start the stop watch:
Press, then release the  key

6. Handling and control

8. Indication of the function:

The predefined time value counts to zero.

6.4 Pilot switch

Fig. 17: The basic functions required for the operation of the device can be controlled with the pilot switch:

- switch the device on,
- Raising and lowering the front window,
- switching the device to OFF mode.

6.4.1 Moving the front window

The movement of the front window is controlled by depressing the pilot switch control element with the corresponding arrow symbol.

1. To raise the window, press the control element [1]. When the front window reaches the working position, the movement stops automatically. If the movement starts above the working position, the front window stops at the maximum opening position.
2. To stop the upward movement, release the control element.
3. To lower the window, keep the control element [2] depressed.
4. To stop the downward movement, release the control element.

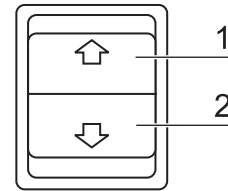

Fig. 15
Basic functions of the pilot switch



NOTE – Switching functions (on/off)

If the device is started with the pilot switch, the chamber illumination is switched on.
If the device is switched off with the pilot switch, the chamber illumination is also switched off.

5. If the front window is not in the working position,
 - the red status indicator **FRONT WINDOW IS NOT IN WORKING POSITION** is illuminated.
 - The audible signal is silenced when the front window is completely closed.
6. When the front window reaches the working position after being moved upwards, the movement stops automatically:
 - The green status indicator **FRONT WINDOW IS IN WORKING POSITION** is illuminated.
 - The audible alarm signal is switched off.

6.**Handling and control****6.4.2 Switching the device to OFF mode**

1. Move the front window to the upper and lower end positions.
2. Release the control element.
3. Keep the previously actuated control element depressed until the ready signal sounds.

**NOTE – Switch-off function**

If the device is switched to the OFF mode with the pilot switch, the chamber illumination is switched off. The device-internal power supply remains in the last functional state that it had been switched to.

7. Operation

7.1 Hygiene preparations for the sample chamber

The sample chamber surfaces and the accessories required for the work process must be disinfected and cleaned in accordance with the hygiene guidelines set forth for the application.

7.2 Preparing the sample chamber

Installing the accessories:

1. Lower the front window completely.
2. Open the front cover or move the front window into the maximum opening position.
3. Position the accessories in the working area of the workplate.
4. Close the front cover.
5. Move the front window to its working position and wait until the airflow has stabilized.



CAUTION – Operational safety!

The personal and material protection is ensured only if the airflow system of the device is working properly.

If the alarm system issues failure messages when the front window is in the working position, stop all applications that may release harmful aerosols!



NOTE – Application of cystostatic agents

For the application of cystostatic agents, the lowered single-part working plate must be used. Application of cystostatic agents.

6. Then place samples into the chamber.
7. To interrupt the work process or for extensive experiment cycles without manual interference, switch the device to standby mode. When the working opening is completely closed, the safety cabinet is sealed aerosol-tight.

7.3 Response to failure messages

Failure messages are displayed in form of text/number combinations with a code between ER 1 and ER 5 (see chapter 6.1.6). If one of these codes is displayed, contact the Technical Service immediately.

To isolate the cause of the failure, the operating personnel must perform only the following tests and measures:

- Check to see if the exhaust air opening on top of the cabinet is blocked.
- Ensure that the on-site exhaust air system is activated.
- Close doors and windows in the laboratory to prevent drafts.
- Switch off devices in the vicinity of the safety cabinet that cause air turbulence or emit excessive heat.
- Open flames in the sample chamber may impair airflow conditions.

7.

Operation

7.4 Work rules

The observance of work rules ensures a minimum of operational safety when handling the safety cabinet.

Before starting an operation:

- Take off jewelry.
- Put on required personal protective gear, e.g. hand, face, or body protection.
- Clean and disinfect sample chamber surfaces at regular intervals.

During operationan:

- Place samples only with in the defined work area of the workplate.
- Do not place unnecessary items into the sample chamber.
- Use only disinfected and cleaned accessories for the work process.
- Do not cause air turbulence, by quick hand, arm or body movement in the sample chamber or in front of the work opening.
- Do not place accessories into the sample chamber that cause air turbulence or emit excessive heat.
- Do not block air circulation at the ventilation slots of the workplate.

Sitting posture during work:

Fig. 16: To prevent risks to health, a height-adjustable working chair with an adjustable seat back should be used during extended work periods at the safety cabinet.

- A** When the forearm rests on the armrest, is should be in an almost horizontal position.
- B** When the thigh is in a horizontal position, the angle between thigh and lower leg should exceed 90°.

To ensure a compensation between floor and sitting height, a Footrest (optional accessory) should be used.

After finishing an operation:

- Remove samples from the sample chamber and store them properly.
- Clean and disinfect the sample chamber surfaces, including the workplate and the floorpan. Clean and disinfect all accessories.

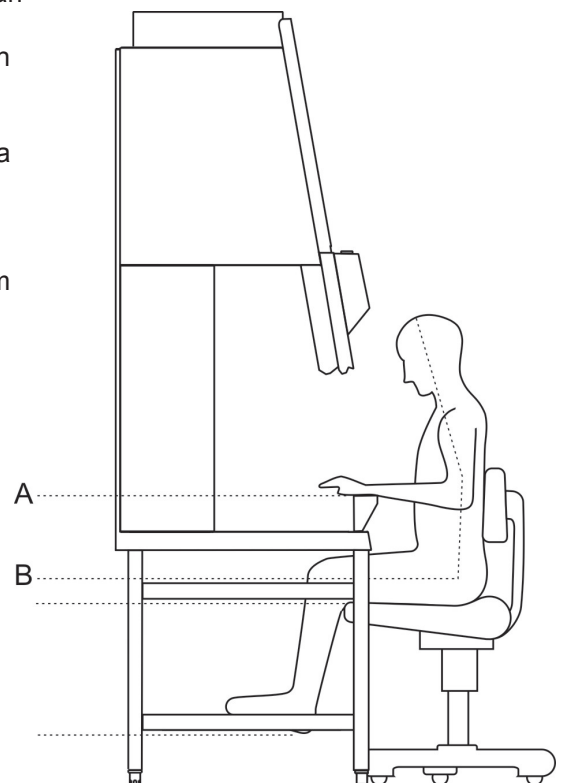

Fig. 16
Sitting posture

8.**Shut-down****8.1 Interrupting an operation**

To interrupt a work process, the device is switched to the OFF mode.

1. Remove all samples from the safety cabinet and store them properly.
2. Remove accessories from the sample chamber and clean and disinfect them.
3. Clean and disinfect the sample chamber surfaces, the workplate, and the floorpan.
4. Switch the device to OFF mode by keeping the ON key depressed until the indicators go off (a dot in the right display segment remains as a voltage signal indicator).

8.2 Shutting the unit down

If the unit is not to be used or stored for an extended period of time, it must be completely decontaminated.

**CAUTION – Decontamination measures!**

To shut the device down, the sample chamber must be disinfected completely and the plenum, including the filters, must be sterilized using formaldehyde.

1. After the device has been decontaminated, close the front window completely.
2. Disconnect the device from the power supply system.

9. Cleaning and decontamination

9.1 Decontamination procedure

Several procedures can be applied for decontaminating the safety cabinet. Which procedure is selected, depends on:

- the potential risk imminent in the agents,
- the degree of purity required by an experiment or by a work process.

Possible decontamination procedures:

Wipe/spray disinfection: is the standard disinfection procedure for cabinets used for microbiological experiments.

UV disinfection: is particularly suited as an intensifying additional disinfection after a wipe/spray disinfection.

Sterilization with steam: can be used for treating the removable stainless steel components. Examples of autoclavable components are the bezels of the UV lamps, the workplate or workplate segments and the armrests.

Disinfection with formaldehyde: can be performed if a sterile scuple chamber is required for the work process. This sterilization procedure is mandatory:

- when filters are replaced,
- when the device is shut down,
- when the device is discarded.

9.2 Wipe/spray disinfection

The wipe/spray disinfection is performed in three stages:

- Predisinfection,
- cleaning,
- final disinfection

Recommended disinfectants:



NOTE – Compatibility

Chloride-containing disinfectants may damage some surfaces. Therefore, use only disinfectants that do not contain chloride!

Disinfectants with an alcohol content of more than 70 % may cause embrittlement of plastic components after extended exposure. Use only disinfectants with a low alcohol content. When using a disinfectant with an alcohol content of more than 70 %, the release limit of 200 g within 2 hours must not be exceeded.

Also suited are disinfectants based on quaternary ammonium compounds.

9. Cleaning and decontamination

Predisinfection:

1. Remove all samples from the sample chamber and store them properly.
2. Remove accessories from the safety cabinet and disinfect them using the disinfection procedure recommended by the manufacturer.
3. The workplate and stainless steel components can be removed from the sample chamber and disinfected separately.
4. For predisinfection, spray disinfectant on all sample chamber surfaces or wipe the surfaces using disinfectant.
5. Do not remove the optional UV lamps from the sockets; wipe them thoroughly using a damp cloth.
6. Switch the device to work mode, move front window to the working position.
7. Allow disinfectant to react as recommended by manufacturer, then operate the safety cabinet for at least 15 to 20 minutes in the work mode so that released aerosols can be absorbed by the filters.

Cleaning:

1. Wipe the surfaces clean using a clean cloth and plenty of clear water.
2. Remove dirt residues and deposits thoroughly.
3. Remove the cleaning liquid from the floorpan and wipe all sample chamber surfaces dry.

Final disinfection:

1. Again, spray disinfectant on all sample chamber surfaces or wipe the surfaces clean with disinfectant.
2. Allow disinfectant to react as recommended by manufacturer.

9.3 UV disinfection after a wipe/spray disinfection

A UV disinfection can be performed either by using the optional integral UV lamps or by using a mobile UV device. The run time of the routine can be preset at the operating panel.

9.3.1 UV disinfection using the integral UV lamps

To start the UV disinfection routine:

1. Remove the stainless steel covers from the lamp mountings in the side walls.
2. Close the front window completely, the air system operates in the reduced mode (yellow LED illuminated).
3. Start UV disinfection using the key  at the operating panel:

Keep the key  depressed until the display alternately shows UV and the remaining disinfection time.

To interrupt / cancel the UV disinfection routine:



Keep the key  depressed until UV is switched off (the display shows the operating hours) or open the front window.

9. Cleaning and decontamination

9.3.2 UV disinfection using a mobile UV device

To control the disinfection routine of a mobile UV device with the safety cabinet software, ensure that the connecting plug of the UV device is compatible with the UV disinfection adapter of the safety cabinet.

To start the UV disinfection routine:





1. Position the mobile UV device centered on the work area and connect to the UV disinfection adapter.
2. Close the front window completely, the air system operates in the reduced mode (yellow LED illuminated).
3. Start UV disinfection using the key  at the operating panel:
Keep the key  depressed until the display alternatingly shows UV and the remaining disinfection time.

To interrupt / cancel the UV disinfection routine:

Keep the key  depressed until UV is switched off (the display shows the operating hours) or open the front window.

9.3.3 Changing the UV disinfection time

The UV disinfection time has been preset but can be changed as required:

1. Switch the safety cabinet on and move the front window to the working position.
2. Keep the key  depressed until the preset time is displayed.
3. To extend the time: Press the key . Each pressing of the key extends the time by 30 minutes.
4. To reduce the time: Press the key  (INTERNAL WORK SPACE ILLUMINATION). Each pressing of the key reduces the time by 30 minutes.
5. To save the value: Press the key . The display indicates the operating hours again.

9. Cleaning and decontamination

9.4 Sterilization with formaldehyde

Procedure:

For sterilization, formaldehyde is evaporated in the tightly sealed sample chamber. The quantity of the formaldehyde used depends on the sample chamber volume of the cabinet version to be disinfected (see Technical Data).

Per cubic meter of sample chamber volume, at least 5 g formaldehyde must be evaporated with 20 ml water (corresponds with 25 ml of a 20 % formaldehyde solution). The formaldehyde evaporates immediately when its boiling point is reached. The required reaction time is at least 6 hours.

After the required reaction time, the formaldehyde should be neutralized by evaporating a 25 % ammonium solution (10 ml per cubic meter of sample chamber volume).

Ambient conditions and accessories:

The temperature at the cabinet location should be approx 21 °C, the relative humidity should be between 60 and 85 %. To evaporate the solution, a heating device with a container is required.

**NOTE – Disinfection procedure**

A sterilization with formaldehyde must be performed in accordance with the specifications of NSF 49/1992, Annex G.

As this procedure has considerable risks, it must only be performed by specially trained and authorized service personnel!

9.5 Cleaning the exterior surfaces

Wipe the exterior surfaces of the device clean using a solution of tepid water and commercial dishwasher solution. Then, wipe exterior surfaces dry using a soft, clean cloth.

9.6 Cleaning the floorpan

Clean the floorpan using a solution of tepid water and commercial dishwasher.

1. Remove the working plates from the sample chamber.
2. Remove dirt residues and deposits thoroughly.
3. Wipe the floorpan clean using a clean cloth and plenty of clear water.
4. Remove the cleaning liquid from the floorpan and wipe the floorpan surfaces thoroughly clean.

**NOTE – Material residues**

After cleaning, make sure that all cleaning materials have been removed completely from the floorpan.

5. Reinstall the working plates.

10.**Maintenance****10.1 Inspection**

PER is the value that indicates the safety state of the safety cabinet by monitoring various device parameters.

- If PER shows a value below 60, the device should be inspected.
- Independent of the PER value, the safety cabinet must be inspected on an annual basis.

The annual inspection comprises the following checks:

- Electrical safety in accordance with national regulations.
- Functional test of the device.
- Checking all components for possible damage.
- Checking the filter state.

**NOTE – Perforated plate**

The Perforated plate at the blanket of the sample chamber serves for the protection of the downflow filter and prevents refluxing. While scanning the filter surface for leak test the perforated plate must be built-in.

- Checking the airflow conditions.
- Repeat test in accordance with NSF 49/1992, Annex F.

10.2 Service**Filter replacement:**

As the filter replacement is an interference with the safety system of the device, filters must only be replaced by Thermo Electron LED GmbH or by adequately trained and authorized service personnel.

**NOTE – Repeat test**

Before filters are replaced the disinfection with formaldehyde is mandatory. After the filter replacement, a repeat test must be performed in accordance with EN 12469 / 2000.

10.2.1 UV lamps

The UV lamps should be replaced after 1500 operating hours:

1. Remove cover from lamp housing.
2. Rotate the lamp in the socket so that the lamp contacts can be removed from the groove in the socket.
3. Insert the new lamp into the socket and rotate until the contacts engage.
4. Replace cover.

10. Maintenance

10.2.2 Sample chamber illumination

The tubes are installed in the front cover bezel.

1. Remove the bezel retaining screws and the bezel.
2. The luminescent tubes are retained by rotatable sockets. Rotate the tube carefully to the removal position and remove it from the socket.
3. Insert the replacement tube and rotate it to the working position.
4. Reinstall the bezel and secure it with the screws.

10.2.3 Replacing the front window seal

Fig. 17: When the front window seal shows visible sign of wear, the seal must be replaced.

The sealing is slipped onto the housing frame and secured by an additional retaining strip at the lower edge of the sample chamber opening.

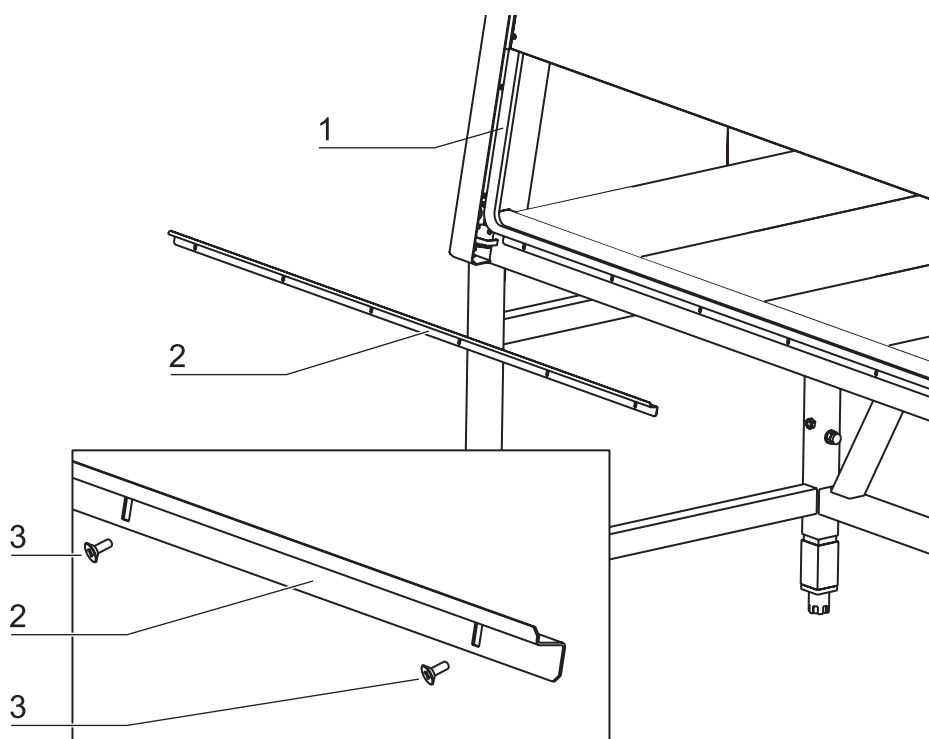

Fig. 17
Front window seal replacement

1. Lower the front window completely and open the front cover.
2. Remove the retaining screws [3] and remove the retaining strip [2].
3. Remove the seal [1] from the housing frame retaining lip.
4. Slip the groove of the new seal onto the housing frame retaining lip and push it on so that the seal fits evenly along the entire sealing surface.
5. Secure the retaining strip with the screws.

10.**Maintenance****10.3 Retrofitting and repairs**

External communication systems, e.g. failure report systems or components for supplying media such as gas solenoid valves can be retrofitted and integrated into the device control.

**NOTE – Retrofitting and repairs**

All retrofitting and repair work are interferences with the safety system of the unit. Particularly modifications to the filter system and resulting changes of the airflow may impair personal and material protection. Such work must be carried out only by authorized service personnel.

11. Disposal

11.1 Disposal procedure

Discarded cabinets or unit components contain reusable materials. All components with the exception of the HEPA filters can be disposed of after having been thoroughly cleaned and disinfected. The HEPA filters must be disposed of in accordance with the applicable national and state regulations for special solid waste.



CAUTION – Contamination hazard!

As the device can be used for processing and treating infectious substances, it may be contaminated. Prior to disposal, the complete device with filters must be decontaminated by performing a formaldehyde sterilization!



Recyclable materials!

Component	Material
Thermal insulation components	Polystyrene foam, EPS/PPS compound
Printed circuit boards	Enclosed electrical components coated with various plastics, mounted on epoxy resin-bound boards.
Plastic components, general	Note material labeling
Exterior housing	Steel, painted
Device backpanel	Stainless steel/steel, painted
Front cover seal	EMPP
Front window, side windows	Multi-layer safety glass
Operating panel and indicator foil	Polyethylene, Polyester
Workplates	Stainless steel
UV bezels	Stainless steel
Armrests	Stainless steel
Batteris (safety feature: Lower Front Window)	Nickel/metal hydrid

11.**Disposal****WEEE Compliance:**

This product is required to comply with the European Union's Waste Electrical & Electronic Equipment (WEEE) Directive 2002/96/EC. It is marked with the following symbol:



Thermo Fisher Scientific has contracted with one or more recycling/disposal companies in each EU Member State, and this product should be disposed of or recycled through them.

Further information on Thermo Fisher Scientific's compliance with these Directives, the recyclers in your country, and information on Thermo products which may assist the detection of substances subject to the RoHS Directive are available at www.thermo.com/WEEERoHS.

12. Technical data

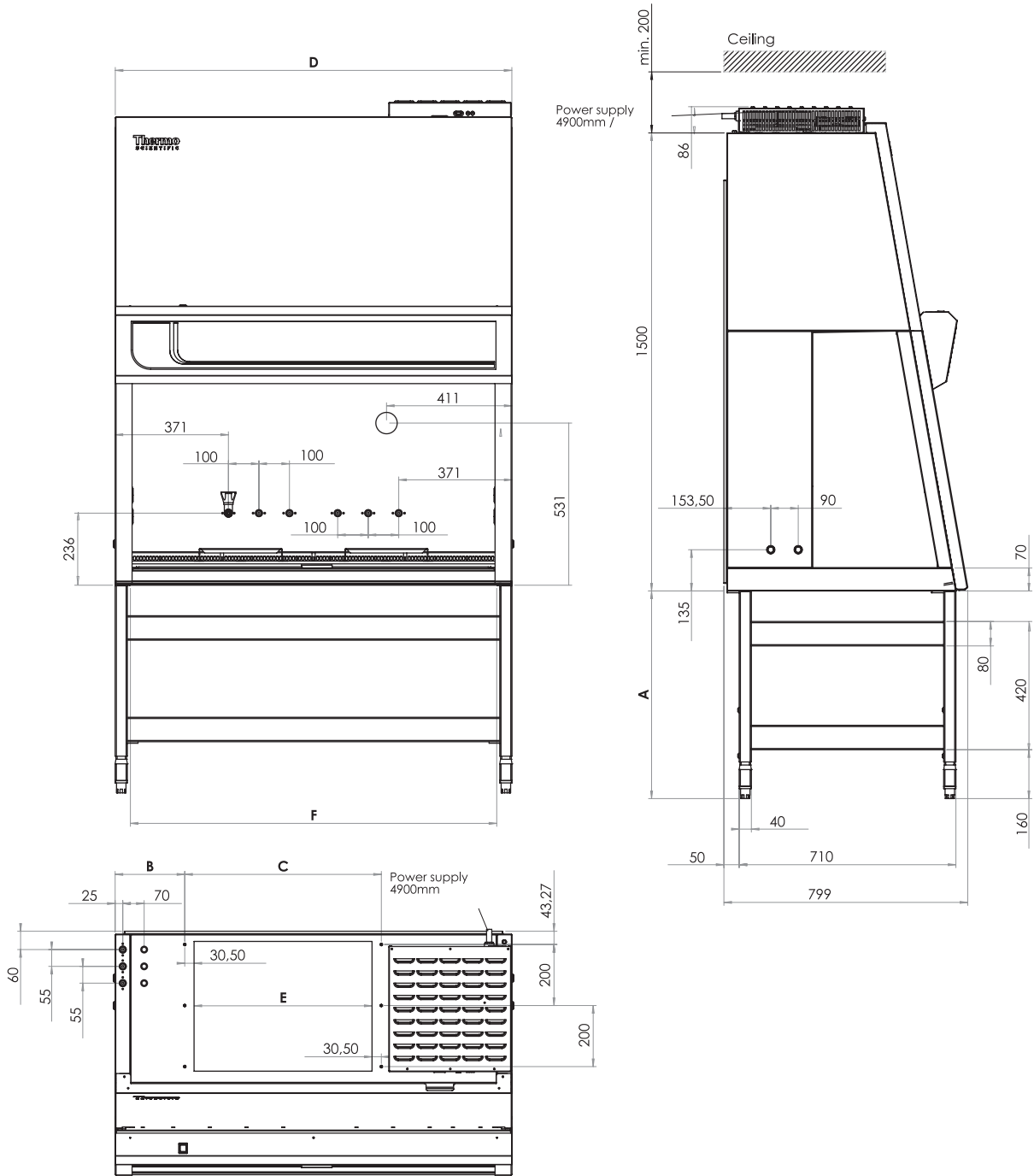

	A
Seated work position	680 mm
Standing work position	880 mm

Attention: With additional gas valves in the side walls, you must plan with more width (dimension D)

	B	C	D	E	F
Safe 2020 0.9	81 mm	491 mm	1000 mm	430 mm	900 mm
Safe 2020 1.2	228 mm	644 mm	1300 mm	583 mm	1200 mm
Safe 2020 1.5	478 mm	644 mm	1600 mm	583 mm	1500 mm
Safe 2020 1.8	474,5 mm	951 mm	1900 mm	890 mm	1800 mm

12.

Technical data

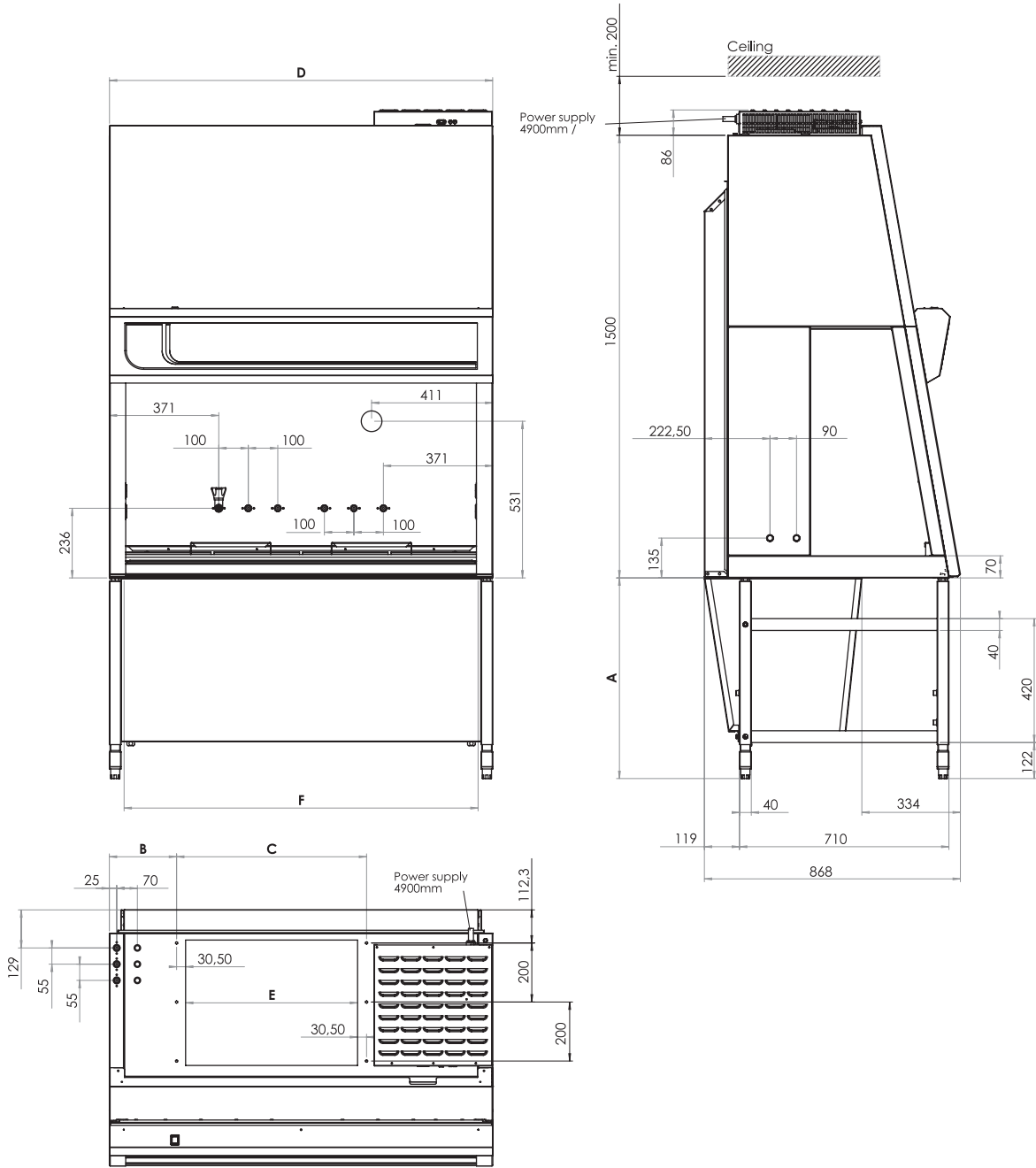

	A
Seated work position	680 mm
Standing work position	880 mm

Attention: With additional gas valves in the side walls, you must plan with more width (dimension **D**)

	B	C	D	E	F
Maxisafe 2020 0.9	81 mm	491 mm	1000 mm	430 mm	900 mm
Maxisafe 2020 1.2	228 mm	644 mm	1300 mm	583 mm	1200 mm
Maxisafe 2020 1.5	478 mm	644 mm	1600 mm	583 mm	1500 mm
Maxisafe 2020 1.8	474,5 mm	951 mm	1900 mm	890 mm	1800 mm

12. Technical data

Dimensions					
Safe 2020 / Maxisafe 2020		0.9	1.2	1.5	1.8
Exterior dimensions					
Width	mm	1000	1300	1600	1900
Depth	mm	800 / 870			
Height without stand	mm	1580			
Interior dimensions					
Width	mm	900	1200	1500	1800
Depth	mm	630			
Height	mm	780			
Front window					
Opening in working position	mm	~200			
Max. opening	mm	780			
Working area height					
Fixed stand	mm	750			
Height-adjustable stand	mm	750 - 950			
Stand height					
Fixed stand	mm	680			
Height-adjustable stand	mm	680 - 880			
Unit height with stand					
Fixed rack	mm	2260			
Height-adjustable stand	mm	2260 - 2460			
Side wall feed throughs					
Diameter	mm	23			
Distance lower edge	mm	130			
Distance from backpanel					
Bushing 1	mm	160			
Bushing 2	mm	250			
Optional media connections in chamber backpanel					
Diameter	inches	R 3/8	R 3/8	R 3/8	R 3/8
Outer distance left					
Connection 1	mm	370			
Connection 2	mm	470			
Connection 3	mm	570			
Outer distance right					
Connection 4	mm	570			
Connection 5	mm	470			
Connection 6	mm	370			

12.

Technical data

Electrical data					
Safe 2020 / Maxisafe 2020		0.9	1.2	1.5	1.8
Voltage					
Rated voltage	V	1/N/PE AC, 230 V - 50/60 Hz			
Blower voltage	V	48 V / DC			
Current					
Power consumption	A	7.3	7.3	8.7	8.7
Leakage current IEC1010,	mA	< 3.5			
Motherboard fusing	A	2 x T 16 A			
Outlet fusing	A	2 x T 5 A			
On-site fusing	A	Circuit breaker B16 / Fuse T 16 A			
Power					
Power input	W	1700	1700	2000	2000
Protection					
Protection class		I			
Protection type		IP 20			
Overvoltage category (IEC 1010, EN 61010)		II			
Contamination degree (IEC 1010, EN 61010)		2			
Connecting lines					
Connecting lines		Cable (4.9 m)			

Pressure					
Safe 2020 / Maxisafe 2020		0.9	1.2	1.5	1.8
Pressure media valves	bar	max. 6			

12. Technical data

Volume, weights, and loads					
Safe 2020					
		0.9	1.2	1.5	1.8
Volume					
Unit volume	m ³	1.1	1.4	1.7	2.1
Floorpan	l	30	40	50	60
Weights					
Cabinet	kg	170	200	230	280
Stand AFS 1	kg	26	26	27	27
Stand AFS 2	kg	30	30	31	31
Electrically operated stand	kg	30	30	31	31
Loads					
Max. load per working area module					
	kg	25			
Max. load on overall working area					
	kg	50	75	75	75
Maxisafe 2020					
		0.9	1.2	1.5	1.8
Volume					
Unit volume	m ³	1.1	1.4	1.7	2.1
Floorpan	l	4	5	6	7.5
Weights					
Cabinet	kg	200	240	280	330
Stand AFS 2	kg	30	30	31	31
Loads					
Max. load per working area module					
	kg	25			
Max. load on overall working area					
	kg	50	75	75	75

12.
Technical data

Airflow system					
Safe 2020 / Maxisafe 2020		0.9	1.2	1.5	1.8
Airflow velocities					
Inflow	m/s	0.45			
Downflow	m/s	0.36			
Air volume					
Overall volume flow	m ³ /h	910	1220	1520	1820
Downflow volume flow	m ³ /h	620	830	1040	1240
Exhaust air volume flow	m ³ /h	290	390	480	580

Filters					
Safe 2020 / Maxisafe 2020		0.9	1.2	1.5	1.8
Type		HEPA (H 14 according to DIN EN 1822)			
Material		Glas fiber fleece			
Separability in MPPS	%	99.995			
Separability at 0.3 µm particle size	%	99.999			
Downflow					
Width	mm	915	1220	1525	1830
Depth	mm	457			
Height	mm	93			
Abluft					
Width	mm	457	610		915
Depth	mm	457	457		457
Height	mm	117	117		117

Primary filter					
Maxisafe 2020		0.9	1.2	1.5	1.8
Type		HEPA (H 14 according to DIN EN 1822)			
Material		Glas fiber fleece			
Separability in MPPS	%	99.995			
Separability at 0.3 µm particle size	%	99.999			
Width	mm		86.5		
Depth	mm		257		
Height	mm		575		

12. Technical data

Ambient conditions					
Safe 2020 / Maxisafe 2020		0.9	1.2	1.5	1.8
Temperature					
Max. ambient temperature during operation	°C	40			
Min. ambient temperature during operation	°C	10			
Humidity					
Max. humidity / operation	% r.H.	90			
Max. humidity / storage	% r.H.	95			
Heat dissipation to environment					
Room temperature 25 °C	W	160/200	200/240	270/310	340/420
Room temperature rise					
Above room temperature with window closed	°K	< 2	< 2	< 2	< 2
Ergonomics					
Noise level	dB(A)	56	56	58	58
		The noise level was determined in accordance with EN ISO3744. The sound pressure level was measured at a distance of 1 m in front of the working opening. The measurement uncertainty is within a range of ± 2 dB.			

14. Certificate of decontamination

Invoice recipient / Customer no.:			Location / Forwarding address:		
Year of manufacturer:	KC:	ST:	Name of technician:	Appointed date:	
order date:	Ordered by:	Order no.:			
Type of device:			ID no. / Order no.:	Operating hours:	
Equipment no.:	Factory no.:	Service device no.:	Date of delivery:	Date of start-up:	Customer inventory no.:

Certificate of decontamination

Dear customer,

when using biological and chemical agents within and outside of devices, hazards to the health of the operating personnel may be present and contamination of the surroundings of the device may occur when service or repair works are carried out.

Within the scope of national and international legal regulations, such as

- responsibility of a company for the protection of its employees,
- responsibility of the operator for the operational safety of devices,

all possible hazards must absolutely be prevented. Prior to any calibration, service, and repair works, prior to any relocation of a device, and prior to the shut-down of a device, the device must be decontaminated, disinfected, and cleaned as required by the work to be carried out. Therefore, we ask you to fill in this certificate of decontamination before you start with the required work.

Yours sincerely

Thermo Electron LED GmbH

Works to be carried out (please mark where applicable)

Service	<input type="checkbox"/>	Filter replacement	<input type="checkbox"/>
Repair	<input type="checkbox"/>	Relocation	<input type="checkbox"/>
Calibration	<input type="checkbox"/>	Transport	<input type="checkbox"/>

Declaration of possible contamination (please mark where applicable)

The device is clear of biological material	<input type="checkbox"/>	The device is clear of dangerous chemical substances	<input type="checkbox"/>
The device is clear of radioactivity	<input type="checkbox"/>	The device is clear of other dangerous substances	<input type="checkbox"/>
The device is clear of cytostatic agents	<input type="checkbox"/>		

Certification:

Prior to carrying out the required work, we have decontaminated, disinfected, and cleaned the device as described in the operating instructions of the device and in accordance with nationally applicable regulations. The device does not present any hazards.

Note:

Date, legally binding signature, stamp

Thermo
S C I E N T I F I C

Internet: <http://www.thermo.com>